

# DISCOURSE 8

*Bible Translation --- The Serpent's "Playground"*



HEBREW -- THE WORD OF GOD -- OLD TESTAMENT

שְׁמַע יִשְׂרָאֵל יְהוָה אֱלֹהֵינוּ יְהוָה אֶחָד: וְאַהֲבָתָא  
יְהוָה אֱלֹהֶיךָ בְּכָל-לֵבְבְךָ וּבְכָל-נַפְשֶׁךָ

AN ENGLISH TRANSLATION

"Hear, O Israel, Jehovah our Gods is Jehovah a unity; and thou shalt love Jehovah thy Gods with all thy heart, and with all thy soul, and with all thy strength" (Deut. 6:4, 5; lit. trans.).

DAVID L. COOPER

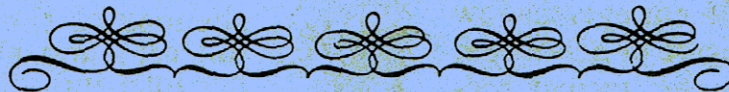

GREEK -- THE WORD OF GOD -- NEW TESTAMENT

ἀκουε, Ἰσραήλ, κύριος ὁ θεὸς ἡμῶν: Ἦ κύριος εἷς ἐστίν, <sup>1</sup>καὶ ἀγαπήσεις κύριον τὸν θεόν σου ἐξ ὅλης <sup>0</sup>τῆς καρδίας σου καὶ ἐξ ὅλης <sup>02</sup>τῆς ψυχῆς σου <sup>□</sup>καὶ ἐξ ὅλης <sup>03</sup>τῆς διανοίας σου <sup>\</sup>καὶ ἐξ ὅλης τῆς ἰσχύος σου<sup>†</sup>. MARK 12:29,30.

AN ENGLISH TRANSLATION

You-be-hearing, Israel, Jehovah our God Jehovah is one.

30 And you-will-cherish Jehovah your God out-of your total heart and out-of your total soul and out-of your total intellect and out-of your total strength. R.H.Mount



# Yea, hath God said?

The New King James Version

The New Testament Text

There is more manuscript support for the New Testament than for any other body of ancient literature. Over five thousand Greek, eight thousand Latin, and many more manuscripts in other languages attest the integrity of the New Testament. There is only one basic New Testament used by Protestants, Roman Catholics, and Orthodox, by conservatives and liberals. Minor variations in hand copying have appeared through the centuries, before mechanical printing began in A.D. 1450.

Some variations exist in the spelling of Greek words, in word order, and in similar details. These ordinarily do not show up in translation and do not affect the sense of the text in any way.

Other manuscript differences, regarding the omission or inclusion of a word or a clause, and two paragraphs in the gospels, should not overshadow the overwhelming degree of *agreement* which exists among the ancient records. Bible readers may be assured that the most important differences in the English New Testament of today are due, not to manuscript divergence, but to the way in which translators view the task of translation: How literally should the text be rendered? How does the translator view the matter of biblical inspiration? Does the translator adopt a paraphrase when a literal rendering would be quite clear and more to the point?

## GENESIS 3 ASV

**3** Now <sup>6</sup>the serpent was more subtle than any beast of the field which Jehovah God had made. And he said unto the woman, Yea, hath God said, Ye shall not eat of <sup>4</sup>any tree of the garden? **2** And the woman said unto the serpent, <sup>7</sup>Of the fruit of the trees of the garden we may eat: **3** but of the fruit of the tree which is in the midst of the garden, God hath said, Ye shall not eat of it, neither shall ye touch it, lest ye die. **4** <sup>9</sup>And the serpent said unto the woman, Ye shall not surely die: **5** for God doth know that in the day ye eat thereof, then your eyes shall be opened, and <sup>h</sup>ye shall be as <sup>5</sup>God, knowing good and evil. **6** <sup>1</sup>And when the woman saw that the tree was good for food, and that it was a delight to the eyes, and that the tree was <sup>6</sup>to be desired to make one wise, she took of the fruit thereof, and did eat; and she gave also unto her husband with her, and he did eat. **7** And the eyes of them both were opened, and they <sup>k</sup>knew that they were naked; and they sewed fig-leaves together, and made themselves <sup>7</sup>aprons. **8** And they heard the <sup>9</sup>voice of <sup>1</sup>Jehovah God walking in the garden in the <sup>9</sup>cool of the day: <sup>m</sup>and the man and his wife hid themselves from the presence of Jehovah God amongst the trees of the garden.

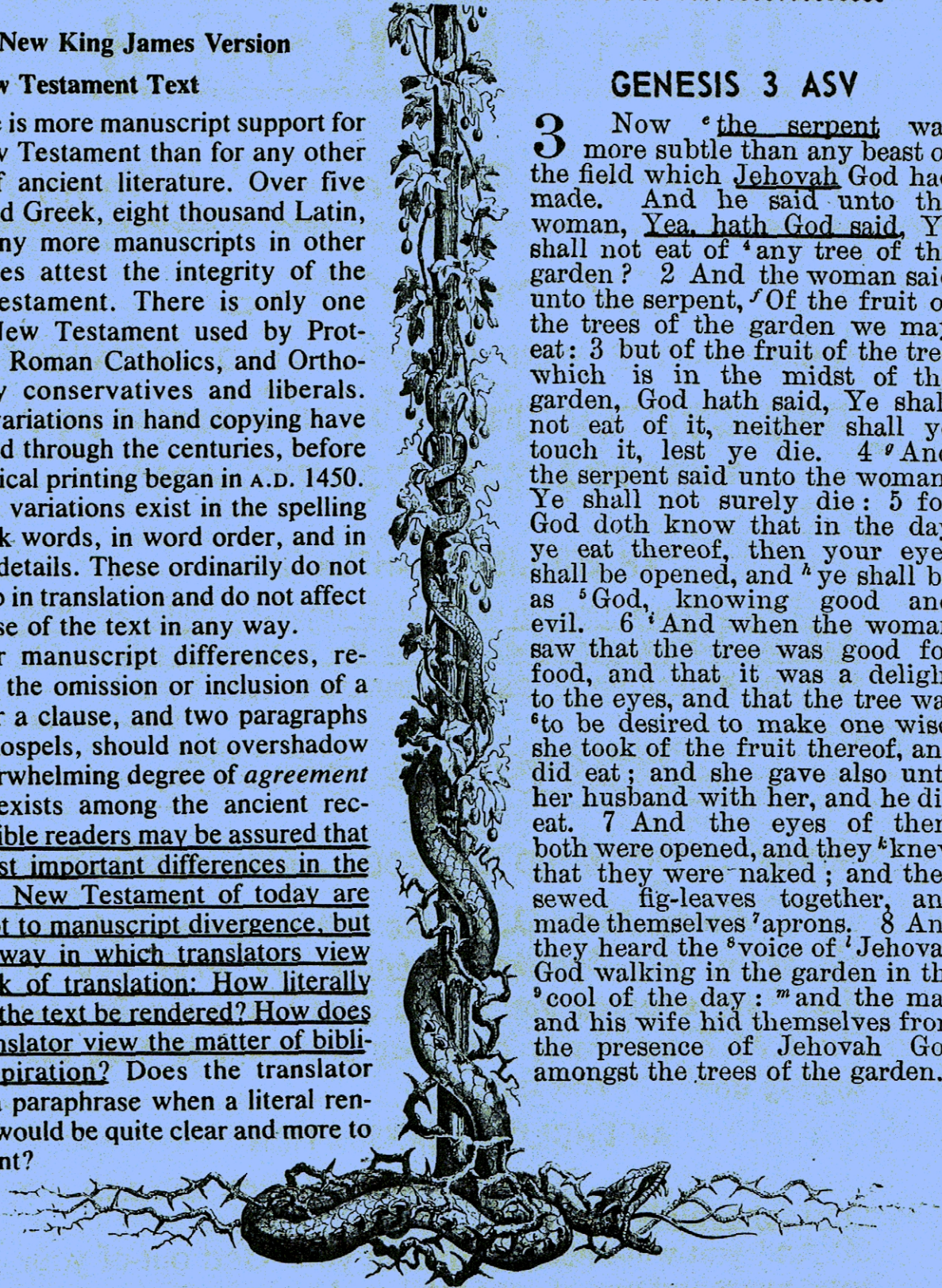

## II CORINTHIANS 11 CT

**3** But I-am-fearing lest by-any-means as the serpent de-luded Eve in his craftiness, thus YOUR thoughts might-be-corrupted from the simplicity and the pureness namely-that with-reference-to Messiah.



THERE ARE PRESENTLY 50 ENGLISH TRANSLATIONS.

ARE THERE 50 DIFFERENT "WORDS OF GOD?"

IT WAS IN THE GARDEN OF EDEN THAT THE SERPENT  
BEGAN TO "PLAY" WITH GOD'S WORD.

REVELATION 12 CT

- \* 1 And a great sign was-seen in the heaven, a woman having-been-and-still-cast-around with the sun, and the moon underneath her feet and on her head a crown of-stars twelve,
- 2 And having in her womb, and suffering-birth-pains she-is-crying and being-tormented to-bring-forth.
- \* 3 And another sign was-seen in the heaven, and behold, a great dragon red-as-fire, having seven heads and ten horns and on his heads seven diadems,
- 4 And his tail is-dragging the third of-the stars of-the heaven, and he-cast them into the earth. And the dragon has-stood-and-still-stands in-sight of-the woman namely-the future one to-bring-forth, in-order-that at-the-time-that she-might-bring-forth he-might-devour her child.

THE CENTER OF THE WARFARE

We must  
identify  
these  
SIGNS. \*

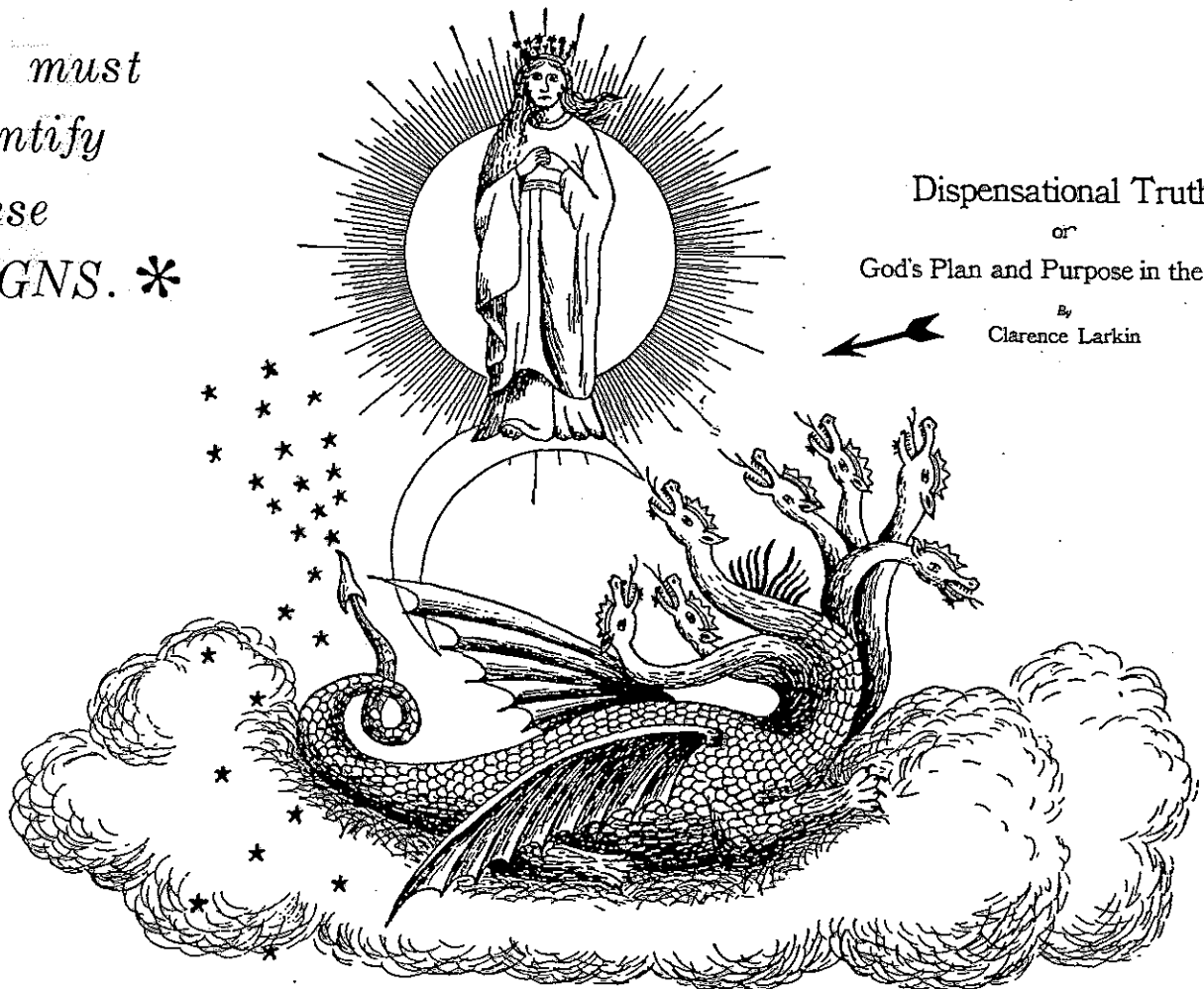

Dispensational Truth  
or  
God's Plan and Purpose in the Ages  
By  
Clarence Larkin

## THE SECOND SIGN IS THE MORE EASILY IDENTIFIED.

### REVELATION 12 CT

7 And it-came-to-pass a war in the heaven, the Michael and his angels to-war with the dragon. And the dragon warred and his angels,

8 And he-was not strong-enough, neither was their place still found in the heaven.

9 And the dragon, namely-the great one, namely-the serpent, namely-the ancient one, the one being-called a slanderer, also the adversary, namely-the one leading- astray the total inhabited-earth, was cast, he-was-cast into the earth, and his angels were-cast with him.

The one leading- astray the total inhabited- earth,  
 ὁ σατανᾶς, the adversary, the dragon, the great,  
 ὁ διάβολος, the slanderer, the serpent, the ancient.

#### King James Version

<sup>9</sup>And the great dragon was cast out, that old serpent, called the Devil and Satan, which deceiveth the whole world; he was cast out into the earth, and his angels were cast out with him.

#### Living Bible

<sup>9</sup>This great Dragon—the ancient serpent called the devil or Satan, the one deceiving the whole world—was thrown down onto the earth with all his army.

#### Today's English Version

<sup>9</sup>The huge dragon was thrown out! He is that old serpent, named the Devil, or Satan, that deceived the whole world. He was thrown down to earth, and all his angels with him.

#### New International Version

<sup>9</sup>The great dragon was hurled down —that ancient serpent called the devil or Satan, who leads the whole world astray. He was hurled to the earth, and his angels with him.



#### Phillips Modern English

So the huge dragon, the serpent of ancient times, who is called the devil and Satan, the deceiver of the whole world, was hurled down upon the earth, and his angels were hurled down with him.

#### Revised Standard Version

<sup>9</sup>And the great dragon was thrown down, that ancient serpent, who is called the Devil and Satan, the deceiver of the whole world—he was thrown down to the earth, and his angels were thrown down with him.

#### New English Bible

So the great dragon was thrown down, that serpent of old that led the whole world astray, whose name is Satan, or the Devil—thrown down to the earth, and his angels with him.

#### Jerusalem Bible

<sup>9</sup>The great dragon, the primeval serpent, known as the devil or Satan, who had deceived all the world, was hurled down to the earth and his angels were hurled down with him.



The serpent, as the slanderer, can not change God's word, but he can alter how translators regard God's word. These 8 translations incorrectly used the English word "world" to translate "oikoumene". The "inhabited-earth" in scripture is the Roman Empire. It should be easy to see that Luke 2:1 in the King James Translation is false. (See The Teaching Dictionary page 213)

#### LUKE 2 KJ

**A**ND it came to pass in those days, that there went out a decree from Cesar Augustus, that all the world should be taxed.

All of the translations above use Devil and Satan as proper names. This hides the adversary's true name ZEUS. (See Devil and Satan in The Teaching Dictionary pages 324 and 345)

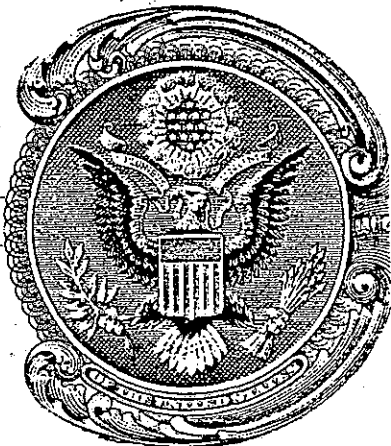

THE ZEUS EAGLE  
 SEAL OF UNITED STATES.



# THE ADVERSARY'S INFLUENCE CAUSES TRANSLATORS TO CHANGE GOD'S PURPOSE FOR A WHOLE BOOK.

## I PETER 1 CT

1 Peter, an apostle of Jesus Messiah to-chosen resident-aliens of dispersion of-Pontus, of-Galatia, of-Cappadocia, of-Asia and of-Bithynia,

### King James Version

1 Peter, an apostle of Jesus Christ, to the strangers scattered throughout Pontus, Galatia, Cappadocia, Asia, and Bithynia,

### Living Bible

1 From: Peter, Jesus Christ's missionary.  
To: The Jewish Christians driven out of Jerusalem and scattered throughout Pontus, Galatia, Cappadocia, Asia, and Bithynia.

### Today's English Version

1 From Peter, apostle of Jesus Christ—  
To God's chosen people who live as refugees scattered throughout the provinces of Pontus, Galatia, Cappadocia, Asia, and Bithynia.

### New International Version

1 Peter, an apostle of Jesus Christ,  
To God's elect, strangers in the world, scattered throughout Pontus, Galatia, Cappadocia, Asia and Bithynia,

### Phillips Modern English

Peter, a messenger of Jesus Christ, sends this letter to God's people now dispersed in Pontus, Galatia, Cappadocia, Asia and Bithynia,

### Revised Standard Version

1 Peter, an apostle of Jesus Christ, To the exiles of the Dispersion in Pontus, Galatia, Cappadocia, Asia, and Bithynia,

### Jerusalem Bible

1 Peter, apostle of Jesus Christ, sends greetings to all those living among foreigners in the Dispersion of Pontus, Galatia, Cappadocia, Asia and Bithynia, who have been chosen,

### New English Bible

1 From Peter, apostle of Jesus Christ, to those of God's scattered people who lodge for a while in Pontus, Galatia, Cappadocia, Asia, and Bithynia—

### RECEPTUS K.J.

ἐκλεκτοῖς παρεπιδήμοις διασπορᾶς  
to [the] elect sojourners of [the] dispersion

### NESTLE

ἐκλεκτοῖς παρεπιδήμοις διασπορᾶς  
to [the] chosen sojourners of [the] dispersion

### WESTCOTT and HORT

ἐκλεκτοῖς παρεπιδήμοις διασπορᾶς  
to chosen (ones) alien residents of dispersion

### YOUNG'S ANALYTICAL CONCORDANCE

- ROAR, to—
- 7. To sound, ἤχέω ēcheō.  
Luke 21. 25 perplexity; the sea and the waves [roaring]
  - 8. To low, bellow, roar, μυκάομαι mukaomai.  
Rev. 10. 3 cried with a loud voice, as (when) a lion roareth.
  - 9. To roar, bellow, howl, bark, ὀρυόμαι oruomai.  
1 Pe. 5. 8 your adversary the devil, as a roaring

### I PETER IS TO JEWISH BELIEVERS.

Next on page 4 consider Israel's **OPPONENT** as a **HOWLING** lion seeking whom to **SWALLOW**.

Compare these 3 interlinears. The Greek texts are alike. Those who put in the English seemed to know the best English word to use.

TAPE 1 SIDE 2

By making 1 Peter 1:1 vague, obscure, or unclear prepares the reader to think that "Satan" is after him personally. Consider 1 Peter 5:8.

### I. PETER, 5.

8 Be sober, be vigilant; because your adversary the devil, as a roaring lion, walketh about, seeking whom he may devour:

### ST. LUKE, 21.

25 ¶ And there shall be signs in the sun, and in the moon, and in the stars; and upon the earth distress of nations, with perplexity; the sea and the waves roaring;

### REVELATION, 10.

3 And cried with a loud voice, as when a lion roareth: and when he had cried, seven thunders uttered their voices.

**DID GOD USE 3 DIFFERENT GREEK WORDS TO MEAN "ROAR", AS IN KING JAMES, BECAUSE HE DID NOT KNOW THE DIFFERENCE?**

**The Consistent Translation uses 3 different English words.**



REMEMBER, FIRST PETER IS TO JEWISH BELIEVERS NOT GENTILES.  
NOTE THE SERPENT INFLUENCE ON SOME TRANSLATORS.

### King James Version

### I Peter 5:8

### Phillips Modern English

8 Be sober, be vigilant; because your adversary the devil, as a roaring lion, walketh about, seeking whom he may devour: 9 Whom resist steadfast in the faith, knowing that the same afflictions are accomplished in your brethren that are in the world.

Be self-controlled and vigilant always, for your enemy the devil is always about, prowling like a lion roaring for its prey. Resist him, standing firm in your faith, remembering that the strain is the same for all your fellow-Christians in other parts of the world.

### Living Bible

8 Be careful—watch out for attacks from Satan, your great enemy. He prowls around like a hungry, roaring lion, looking for some victim to tear apart. 9 Stand firm when he attacks. Trust the Lord; and remember that other Christians all around the world are going through these sufferings too.

### Revised Standard Version

8 Be sober, be watchful. Your adversary the devil prowls around like a roaring lion, seeking some one to devour. 9 Resist him, firm in your faith, knowing that the same experience of suffering is required of your brotherhood throughout the world.

### Today's English Version

8 Be alert, be on watch! Your enemy, the Devil, roams around like a roaring lion, looking for someone to devour. 9 Be firm in your faith and resist him, because you know that your fellow believers in all the world are going through the same kind of sufferings.

### Jerusalem Bible

8 Be calm but vigilant, because your enemy the devil is prowling around like a roaring lion, looking for someone to eat. 9 Stand up to him, strong in faith and in the knowledge that your brothers all over the world are suffering the same things.

### New International Version

8 Be self-controlled and alert. Your enemy the devil prowls around like a roaring lion looking for someone to devour. 9 Resist him, standing firm in the faith, because you know that your brothers throughout the world are undergoing the same kind of sufferings.

### New English Bible

Awake! be on the alert! Your enemy the devil, like a roaring lion, prowls round looking for someone to devour. Stand up to him, firm in faith, and remember that your brother Christians are going through the same kinds of suffering while they are in the world.

### BRITANNICA Vol.23, Page 465

Cats are noted for their purring when apparently content and for their snarling, howling, or spitting when in conflict with another member of their kind. The larger forms, especially the lion, often roar, growl, or shriek. Usually, however, cats are silent.

### BOOK OF KNOWLEDGE Vol.2

Like other Carnivora, they have hooked claws, not nails, and teeth which tear and chop or shear like scissors, but do not masticate (chew).

### THE ADVERSARY

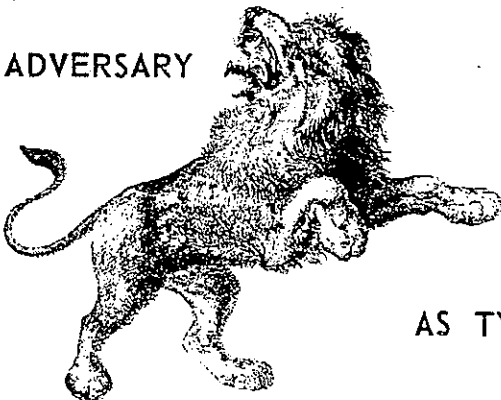

AS TYPES

Added to that it has the most stupendous voice in nature; its ground-shaking roars unnerve animals so that they are often incapable of fleeing.

In general the lion gains its food by its stealth and power rather than by its agility. This huge cat sometimes goes abroad by day but it is chiefly active at night.

Note these few characteristics of lions and compare to lions in scripture. The Consistent Translation is a word for word translation. Does it make any difference?

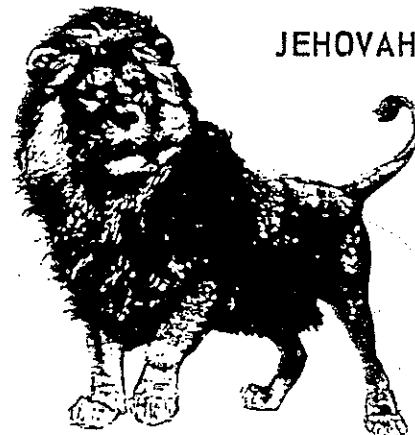

JEHOVAH



AMOS 3 ASV

**3** Hear this word that Jehovah hath spoken against you, O children of Israel, against the whole family which I brought up out of the land of Egypt, saying, 2 'You only have I known of all the families of the earth: therefore I will visit upon you all your iniquities. 3 Shall two walk together, except they have agreed? 4 Will a lion roar in the forest, when he hath no prey? will a young lion cry out of his den, if he have taken nothing? 5 Can a bird fall in a snare upon the earth, where no gin is set for him? shall a snare spring up from the ground, and have taken nothing at all? 6 Shall the trumpet be blown in a city, and the people not be afraid? shall evil befall a city, and Jehovah hath not done it? 7 Surely the Lord Jehovah will do nothing, except he reveal his secret unto his servants the prophets. 8 The lion hath roared; who will not fear? The Lord Jehovah hath spoken; 'who can but prophesy?

YOUR (plural) opponent, that is, Israel's.  
A HOWLING LION--in the presence of another lion, JEHOVAH.

TO-SWALLOW, a lion doesn't chew.  
 Israel's sufferings to be accomplished.

Written about  
 60 A. D.

HOSEA 11 ASV

8 'How shall I give thee up, Ephraim? how shall I cast thee off, Israel? how shall I make thee as Admah? how shall I set thee as Zeboiim? my heart is turned within me, my compassions are kindled together. 9 I will not execute the fierceness of mine anger, I will not return to destroy Ephraim: for I am God, and not man; the Holy One in the midst of thee; and I will not come in wrath. 10 They shall walk after Jehovah, who will roar like a lion; for he will roar, and the children shall come trembling from the west. 11 They shall come trembling as a bird out of Egypt, and as a dove out of the land of Assyria; and I will make them to dwell in their houses, saith Jehovah.

I PETER 5 CT

8 YOU-be-sober, YOU-watch. YOUR opponent a slanderer is-walking-around as a howling lion seeking whom to-swallow;  
 9 Whom YOU-withstand solid ones in-the trust, knowing-absolutely the same of-the sufferings to-be-accomplished in YOUR brotherhood in the world.

ANTISEMITISM

HOW MUCH AUTHORITY DOES THE ADVERSARY HAVE?

LUKE 22 CT

28 But YOU yourselves-are the-ones having-remained-and-still-remaining-continuously with me in my trials. 29 And-I myself-am-covenanting to-YOU a kingdom, according-as my Father himself-covenanted to-me, 30 In-order-that YOU-might-be-eating and YOU-might-be-drinking on my table in my kingdom, and YOU-might-yourselves-be-seated on thrones judging the twelve tribes of-the Israeli. 31 But the Lord said, Simon, Simon, behold, the adversary demanded YOU, to-sift as the wheat; 32 But I myself-petitioned concerning you, in-order-that your trust might not be-disappearing; and at-what-time having-turned-around you yourself-fix-firmly your brothers.

AMOS 9 ASV

9 For, lo, I will command, and I will sift the house of Israel among all the nations, like as grain is sifted in a sieve, yet shall not the least kernel fall upon the earth. 10 All the sinners of my people shall die by the sword, who say, The evil shall not overtake nor meet us.

See The Teaching Dictionary, page 265

Note the plural YOU, all the disciples.

IF YOU BELIEVE THAT THE BIBLE IS GOD'S WORD COMPARE THESE TWO PASSAGES IN THE CT.

MATTHEW 4 CT

8 Again the slanderer is-taking him alongside-with-himself into a very high mountain, and he-is-pointing-out to-him all the kingdoms of-the world and their glory, 9 And he-is-saying to-him, I-shall-give to-you all these-things if having-fallen you-will-worship to-me.

Inhabited-earth----authority and glory  
 World----glory

LUKE 4 CT

5 And the slanderer having-led him up into a high mountain he-pointed-to all the kingdoms of-the inhabited-earth for-him in a point of-time. 6 And the slanderer said to-him, I-shall-give to-you quite-all this authority and their glory; because it-has-been-and-is-still-given-over to-me, and to-whom if I-am-willing I-am-giving it.



# COMPARE THESE 8 TRANSLATIONS OF LUKE 4.

## King James Version

<sup>5</sup>And the devil, taking him up into a high mountain, shewed unto him all the kingdoms of the world in a moment of time. <sup>6</sup>And the devil said unto him, All this power will I give thee, and the glory of them: for that is delivered unto me; and to whomsoever I will, I give it.

## Living Bible

<sup>5</sup> Then Satan took him up and revealed to him all the kingdoms of the world in a moment of time; <sup>6, 7</sup> and the devil told him, "I will give you all these splendid kingdoms and their glory — for they are mine to give to anyone I wish —

## Today's English Version

<sup>5</sup> Then the Devil took him up and showed him in a second all the kingdoms of the world. <sup>6</sup> "I will give you all this power, and all this wealth," the Devil told him. "It was all handed over to me and I can give it to anyone I choose.

## New International Version

<sup>5</sup> The devil led him up to a high place and showed him in an instant all the kingdoms of the world. <sup>6</sup> And he said to him, "I will give you all their authority and splendor, for it has been given to me, and I can give it to anyone I want to.

## Phillips Modern English

Then the devil took him up and showed him all the kingdoms of mankind in a sudden vision, and said to him,

"I will give you all this power and magnificence, for it belongs to me and I can give it to anyone I please.

## Revised Standard Version

<sup>5</sup>And the devil took him up, and showed him all the kingdoms of the world in a moment of time, <sup>6</sup>and said to him, "To you I will give all this authority and their glory; for it has been delivered to me, and I give it to whom I will.

## Jerusalem Bible

<sup>5</sup> Then leading him to a height, the devil showed him in a moment of time all the kingdoms of the world <sup>6</sup> and said to him, "I will give you all this power and the glory of these kingdoms, for it has been committed to me and I give it to anyone I choose.

## New English Bible

Next the devil led him up and showed him in a flash all the kingdoms of the world. "All this dominion will I give to you," he said, "and the glory that goes with it; for it has been put in my hands and I can give it to anyone I choose.



"Inhabited-earth"

does not ever appear.

"Authority" is used only twice.

## THEOLOGICAL DICTIONARY OF THE NEW TESTAMENT

There is within the NT no disputing of the political "oikoumene" understanding of the Roman Empire, not even in Revelation.

### KING JAMES

*οἰκουμένη, oikoumenee.*

Mat.24:14. shall be preached in all the world

Lu. 2: 1. that all the world should be taxed.

4: 5. unto him all the kingdoms of the world  
21:26. which are coming on the earth:

Acts 11:28. dearth throughout all the world:

17: 6. have turned the world upside down

31. in the which he will judge the world

19:27. whom all Asia and the world worshippeth.

24: 5. amogn all the Jews throughout the world,

Ro. 10:18. their words unto the ends of the world.

Heb 1: 6. the firstbegotten into the world,

2: 5. not put in subjection the world to come,

Rev. 3:10. which shall come upon all the world,

12: 9. which deceiveth the whole world:

16:14. kings of the earth and of the whole world,

NEVER TRANSLATED CORRECTLY.

THE SIXTH WORLD POWER ROME.

Jesus did not deny "Satan's" authority. (Luke 4:6 CT) But note Mark 10:35-40.

### ORIGINS

ERIC PARTRIDGE

3. Gr *oikos* has derivative *oikein*, to live in (a house), to inhabit, with pp *oikoumenos*, whence *oikoumenē* (*gē*), the inhabited world, with its own adj *oikoumenikos*, LL *oecūmenicus*, E *ecumenic*, usu in extn *ecumenical*, world-wide, esp concerning the Church as a whole.

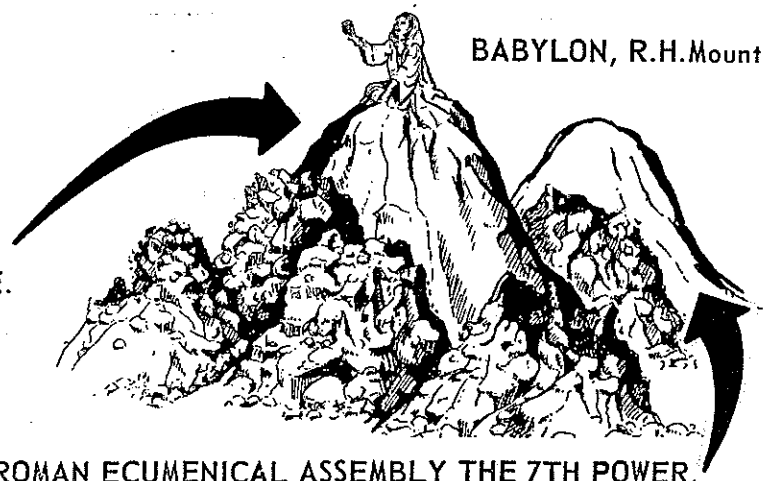

THE SLANDERER "PLAYS" WITH THE TRANSLATORS.

# HOW DOES SATAN EXERCISE HIS AUTHORITY?

As a "HOWLING" lion (p.4) Satan can only be one place at a time.

## REVELATION 12 CT

7 And it-came-to-pass a war in the heaven, the Michael and his angels to-war with the dragon. And the dragon warred and his angels,

8 And he-was not strong-enough, neither was their place still found in the heaven.

9 And the dragon, namely-the great one, namely-the serpent, namely-the ancient one, the one being-called a slanderer, also the adversary, namely-the one leading- astray the total inhabited-earth, was cast, he-was-cast into the earth, and his angels were-cast with him.

\* The word demon is not used in the KJ. The adversary has concealed demon activity, as well as his name Zeus.

### NEW ANALYTICAL GREEK LEXICON

δεισιδαιμων, ον [§7.G.a] (δειδω, to fear, and

\* δαιμων) reverencing the gods and divine things, religious; in a bad sense, superstitious; in N.T. careful and precise in the discharge of religious services, Acts 17:22



\*

THE WORD DEMON APPLIES TO THE GODS OF IDOLATRY, THE ADVERSARY'S ANGELS. THE TRANSLATORS USE SUPERSTITIOUS AND RELIGIOUS BECAUSE OF DISBELIEF IN DEMONS.

### King James Version

22 Then Paul stood in the midst of Mars' hill, and said, Ye men of Athens, I perceive that in all things ye are too superstitious. 23 For as I passed by, and beheld your devotions, I found an altar with this inscription, TO THE UNKNOWN GOD. Whom therefore ye ignorantly worship, him declare I unto you.

### Living Bible

22 So Paul, standing before them at the Mars Hill forum, addressed them as follows: "Men of Athens, I notice that you are very religious, 23 for as I was walking I saw your many altars, and one of them had this inscription on it—'To the Unknown God.' You have been worshipping him without knowing who he is, and now I wish to tell you about him.

### Today's English Version

22 Paul stood up in front of the meeting of the Areopagus and said, "Men of Athens! I see that in every way you are very religious. 23 For as I walked through your city and looked at the places where you worship, I found also an altar on which is written, 'To an Unknown God.' That which you worship, then, even though you do not know it, is what I now proclaim to you.

### New International Version

22 Paul then stood up in the meeting of the Areopagus and said: "Men of Athens! I see that in every way you are very religious. 23 For as I walked around and observed your objects of worship, I even found an altar with this inscription: 'TO AN UNKNOWN GOD.' Now what you worship as something unknown I am going to proclaim to you.

## LUKE 10 CT

17 But the seventy returned with joy, saying, Lord, even the little-demons are-themselves-being-subject to-us in your name.

18 But he-said to-them, I-was-observing the adversary as a-beam-of-light having-fallen out-of the heaven.

## ACTS 17 CT

22 But Paul having-been-stood in midst of-the hill of-Mars was stating: Men Athenians, I-am-observing YOU according-to all-things as most-dreading-of-demons. \*

23 For going-through and observing-again, YOUR venerated-objects I-found also an elevated-place in which had-been-inscribed: To-an-unknown god. What therefore YOU-are-showing-piety being-ignorant, this I myself-am-proclaiming to-YOU.

### ORIGINS

\* E demon, a spirit, esp 'one's good angel', now usu daimon, comes, via LL daemon, from Gr daimōn (δαίμων), a protective spirit, a divinity, perh from daiomai, I distribute, a divinity being a distributor of fate; cf DEAL, para 1. But demon, an evil spirit, seems to have come from LL daemonium, from Gr daimonion, neu of daimonios, adj of daimōn.

### Acts 17:22



### Jerusalem Bible

"Men of Athens, I have seen for myself how extremely scrupulous you are in all religious matters, 23 because I noticed, as I strolled around admiring your sacred monuments, that you had an altar inscribed: To An Unknown God. Well, the God whom I proclaim is in fact the one whom you already worship without knowing it.

### Phillips Modern English

So Paul got to his feet in the middle of their council, and began, "Gentlemen of Athens, my own eyes tell me that you are in all respects an extremely religious people. For as I walked through your city looking at your shrines, I even found one altar on which were inscribed the words, TO GOD THE UNKNOWN. It is this God whom you are worshipping in ignorance that I am here to proclaim to you!

### Revised Standard Version

22 So Paul, standing in the middle of the Areopagus, said: "Men of Athens, I perceive that in every way you are very religious. 23 For as I passed along, and observed the objects of your worship, I found also an altar with this inscription, 'To an unknown god.' What therefore you worship as unknown, this I proclaim to you.

### New English Bible

Then Paul stood up before the Court of Areopagus and said: "Men of Athens, I see that in everything that concerns religion you are uncommonly scrupulous. For as I was going round looking at the objects of your worship, I noticed among other things an altar bearing the inscription 'To an Unknown God.' What you worship but do not know—this is what I now proclaim.





SEPTUAGINT (LXX Psalms 95:5)  
THAT ALL THE GODS OF THE GENTILES ARE DEMONS.

5 ὅτι πάντες οἱ θεοὶ τῶν ἔθνῶν δαιμόνια,

HISTORY OF GREECE (Vol.1 p.383; Vol.3 p.450)

With the heroes who, sons of a divine father and a mortal mother, make a connecting link between earth and heaven, are classed the daimons, of whom Hesiod has already spoken, and of whom we shall again hear under the topic of the worship of the dead.

To the mind of Homer, then, the daimon is, when the word is not applied to an Olympian, a super-terrestrial power without name or form, having no place in the celestial hierarchy, but a sharer in the divine essence.



ZEUS.<sup>1</sup>



AGATHODAIMON.<sup>2</sup>

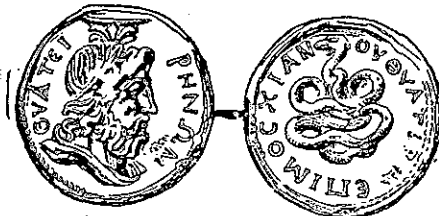

BRONZE COIN.<sup>3</sup>

<sup>1</sup> Zeus upon his throne, holding the sceptre; at his feet, the eagle. (Engraved cornelian, 12 millim. by 10; *Cabinet de France*, No. 1,419.)

<sup>2</sup> Coin of Egyptian Alexandria.

Pausanias (viii. 76) saw in Arkadia, on the road from Megalopolis to Mainale, a temple Ἀγαθοῦ θεοῦ. In Alexandria, the syncretic, Agathodaimon, doubtless Serapis, the Great Healer, is represented under the form of a serpent, the constant companion of Asklepias. Our coin, with the effigy of Nero, was struck at Alexandria, and bears the legend: NEO. ΑΓΑΘΟ ΔΑΙΜΩΝ. (*Cabinet de France*, No. 911.)

<sup>3</sup> Coin of Thyateira, in Lydia. ΘΥΑΤΕΙΡΗΝΩΝ; head of Zeus Serapis, right profile. Reverse: ΕΠΙ ΜΟΧΙΑΝΟΥ ΘΥΑΤΕΙ[ΡΗΝΩΝ]; the serpent Agathodemon rearing its head.

GENESIS 6 ASV

6 And it came to pass, when men began to multiply on the face of the ground, and daughters were born unto them, 2 that the sons of God saw the daughters of men that they were fair; and they took them wives of all that they chose. 3 And Jehovah said, My Spirit shall not strive with man for ever, 4 for that he also is flesh: 5 yet shall his days be a hundred and twenty years. 4 The Nephilim were in the earth in those days, and also after that, when the sons of God came in unto the daughters of men, and they bare children to them: the same were the mighty men that were of old, the men of renown.

RAND McNALLY  
 BIBLE ATLAS p.470

The particular patron of Thyateira was a heroic figure of uncertain origin named Tyrinnos, who is portrayed as riding forth on his charger with a battle-ax over his shoulder. This hero was merged with Apollo and subsequently appears on coins as a standing rather than a mounted figure, but still carrying the ax. He was a "propolis" god, having his temple outside the city walls. The goddess most prominently worshipped was Artemis; curiously the high-priest of the "Pythian-Tyrimnaean-Apollo" and the highpriestess of the "Borcitene Artemis" (as these deities were officially called) were husband and wife.

REVELATION 9 CT

20 And the others of-the MEN, the ones who were not killed in these blows, neither repented-they out-of the works of-their hands, in-order-that they-will not worship the little-demons and the idols, namely-the ones made-of-gold and the one made-of-silver and the ones made-of-brass and the ones of-stone and the ones made-of-wood, which are neither able to-be-looking nor to-be-hearing nor to-be-walking-around,

21 And they-repented not out-of their murders neither out-of their use-of-drugs nor out-of their prostitution nor out-of their thefts.

REVELATION 2 CT

24 But to-YOU I-am-saying, namely to-the-others, namely-to-the-ones in Thyatira, as-many-as are not holding this doctrine, they-who came not to-know the deep things of-the adversary, as they-are-saying: I-am not casting on YOU another weight;

DISCOURSE 5

APOLOGETICS 42

DISCOURSE 6

DISCOURSE 7

ISAIAH 14 ASV

HISTORY OF GREECE By VICTOR DURUY 1892 Vol.1 p.345

Zeus, the supreme god,<sup>3</sup> whom the other divinities obeyed, the protector of the whole Hellenic race, Ζεὺς Πανελληνίος,<sup>4</sup> who was also called, like the Jehovah of the Old Testament, the Highest,

ὑψιστος;

<sup>4</sup> Pausanias, i. 18, 9. The three Peliades, or priestesses of Dodona, were thus invoked: Ζεὺς ἦν, Ζεὺς ἐστίν, Ζεὺς ἔσσεταί, ὦ μέγαλε Ζεῦ (*Id.*, x. 12, 10). In Attika and the Peloponnesos Zeus often received the surnames ὑπατος, ὑψιστος (*Id.*, i. 26, 5; iii. 17, 6; v. 15, 5, etc.).

12 How art thou fallen from heaven, O day-star, son of the morning! how art thou cut down to the ground, that didst lay low the nations! 13 And thou saidst in thy heart, I will ascend into heaven, I will exalt my throne above the stars of God; and I will sit upon the mount of congregation, in the uttermost parts of the north; 14 I will ascend above the heights of the clouds; I will make myself like the Most High.

DO NOT ASSUME THAT THE WAR WHICH BEGAN IN HEAVEN IS OVER. THE ADVERSARY'S ANGELS WERE CAST TO EARTH WITH HIM (PAGE 2). THE DEMONS ARE BACK OF THE IDOLS. (REV. 9:20, PAGE 8). THE DEMONS ARE THE ADVERSARY'S ANGELS. (PAGE 7).

## EPHESIANS 6 CT

11 YOU-clothe-yourselves-in the full-armor of-the God toward YOUR being-able to-stand to the methods of-the slanderer;

12 Because the wrestling for-us is not with blood and flesh, BUT with the principalities, with the authorities, with the world-rulers of this darkness, with the spiritual things of-the evil in the heavenlies.

13 Because-of this YOU-take-up the full-armor of-the God, in-order-that YOU-might-be-able to-withstand in the day namely the evil, and having-worked-out quite-all things, to-stand.

## COLOSSIANS 2 CT

18 Let no-one be-defrauding YOU of-the-prize, willing in humbleness-of-opinion and religion of-the angels, intruding which-things he-has not seen-and-still-does-not-see, being-inflated at-random by the mind of-his flesh,

## ROMANS 8 CT

38 For I-have-been-and-am-still-persuaded that neither death nor life nor angels nor principalities,

39 Nor high-thing nor depth nor any different creation will-be-able to-separate us from the charity of-the God, the charity in Messiah Jesus our Lord.

## THE SERPENT FORM OF THE ADVERSARY OPERATES THROUGH HUMANS.

## II CORINTHIANS 11 CT

13 For the ones such-as-these are false-apostles, treacherous workmen, transfiguring-themselves into apostles of-Messiah.

14 And no marvel, for the adversary is-transfiguring-himself into an angel of-light.

15 Therefore it-is not a great-thing if his ministers also are-transfiguring-themselves as ministers of-justice; of-whom the finish will-be according-to their works.



## I TIMOTHY 4 CT

1 But the Spirit is-saying explicitly that in later seasons some will-depart of-the trust; paying-attention to-misleading spirits and to-teachings of-little-demons.

2 In hypocrisy of-false-wordings;

9 The word is trustworthy and worthy of-all acceptance;

I believe that the misleading spirits and demons teach error by "false-wordings" of scripture. Compare these 8 translations

SEE THE TEACHING DICTIONARY-PAGES 292-295. "FALSE-APOSTLE, FALSE-TEACHER, FALSE-PROPHET, FALSE-WITNESS." WHY NOT FALSE-WORDING?

## King James Version

4 Now the Spirit speaketh expressly, that in the latter times some shall depart from the faith, giving heed to seducing spirits, and doctrines of devils; 2 Speaking lies in hypocrisy;

## Living Bible

4 But the Holy Spirit tells us clearly that in the last times some in the church will turn away from Christ and become eager followers of teachers with devil-inspired ideas. 2 These teachers will tell lies with straight faces and do it so often that their consciences won't even bother them.

## Today's English Version

4 The Spirit says clearly that some men will abandon the faith in later times; they will obey lying spirits and follow the teachings of demons. 2 These teachings come from the deceit of men who are liars,

## New International Version

4 The Spirit clearly says that in later times some will abandon the faith and follow deceiving spirits and things taught by demons. 2 Such teachings come through hypocritical liars,



## Phillips Modern English

God's Spirit specifically tells us that in later days there will be men who abandon the true faith and allow themselves to be spiritually seduced by teachings of demons, teachings given by men who are lying hypocrites.

## Revised Standard Version

4 Now the Spirit expressly says that in later times some will depart from the faith by giving heed to deceitful spirits and doctrines of demons, 2 through the pretensions of liars

## Jerusalem Bible

4 The Spirit has explicitly said that during the last times there will be some who will desert the faith and choose to listen to deceitful spirits and doctrines that come from the devils; 2 and the cause of this is the lies told by hypocrites

## New English Bible

4 The Spirit says expressly that in after times some will desert from the faith and give their minds to subversive doctrines inspired by devils, through the specious falsehoods of men.



THE "TWISTING" OF SCRIPTURE BEGAN EARLY IN THE EPHESUS ASSEMBLY.  
JESUS CALLED HIS GENERATION A "TWISTED GENERATION." (Mat.17:17).

#### ACTS 20 CT

30 Even out-of YOU yourselves men will-stand-up-for-themselves speaking things-having-been-and-still-twisted to-be-pulling-back the disciples behind themselves.

#### King James Version

<sup>30</sup> Also of your own selves shall men arise, speaking perverse things, to draw away disciples after them.

#### Living Bible

<sup>30</sup> Some of you yourselves will distort the truth in order to draw a following.

#### Today's English Version

<sup>30</sup> The time will come when some men from your own group will tell lies to lead the believers away after them.

#### New International Version

<sup>30</sup> Even from your own number men will arise and distort the truth in order to draw away disciples after them.

#### II CORINTHIANS 2 CT

17 For we are not as the many adulterating the word of the God for filthy-lucre, BUT as out-of sincerity, BUT we are speaking as out-of God completely-in-sight of-God in Messiah.

#### King James Version

<sup>17</sup> For we are not as many, which corrupt the word of God: but as of sincerity, but as of God, in the sight of God speak we in Christ.

#### Living Bible

<sup>17</sup> Only those who, like ourselves, are men of integrity, sent by God, speaking with Christ's power, with God's eye upon us. We are not like those hucksters—and there are many of them—whose idea in getting out the Gospel is to make a good living out of it.

#### Today's English Version

<sup>17</sup> We are not like so many others, who handle God's message as if it were cheap merchandise; but because God has sent us, we speak with sincerity in his presence, as servants of Christ.

#### New International Version

<sup>17</sup> Unlike so many, we do not peddle the word of God for profit. On the contrary, in Christ we speak before God with sincerity, like men sent from God.

THE ADVERSARY MET DEFEAT AT THE CROSS BUT BEGAN A CONTINUOUS ATTACK AGAINST THE APOSTLES. (PAGE 5). IT WAS HE AND HIS DEMONS THAT BEGAN THE ATTACK AGAINST THE ASSEMBLY AT EPHESUS. THE "TWISTING" AND "ADULTERATING" OF SCRIPTURE BEGAN AT ONCE. YOU HAVE SEEN 8 DIFFERENT COMPARISONS OF TODAY'S TRANSLATIONS ALTERED BY HIS INFLUENCE OVER TRANSLATORS.

#### Westcott and Hort Interlinear

λαλοῦντες                      διεστραμμένα  
speaking                      having been twisted (things)

#### Phillips Modern English

Yes, and even from among you men will arise speaking per-versions of the truth, trying to draw away the disciples and make them followers of themselves.

#### Revised Standard Version

<sup>30</sup> and from among your own selves will arise men speaking perverse things, to draw away the disciples after them.

#### Jerusalem Bible

<sup>30</sup> Even from your own ranks there will be men coming forward with a travesty of the truth on their lips to induce the disciples to follow them.

#### New English Bible

Even from your own body there will be men coming forward who will distort the truth to induce the disciples to break away and follow them.

§ LXIII SYNONYMS OF THE NEW TESTAMENT 217  
Cheating, we see, and adulterating is part of the notion of *καπηλεύειν*, but the essential of it is sordid lucre.

#### Phillips Modern English

Who is fit for such a task! We are not like that large number who corrupt the Word of God. No, we speak in utter sincerity as men sent by God, Christ's ministers under the eyes of God.

#### Revised Standard Version

<sup>17</sup> For we are not, like so many, peddlers of God's word; but as men of sincerity, as commissioned by God, in the sight of God we speak in Christ.

#### Jerusalem Bible

<sup>17</sup> At least we do not go around offering the word of God for sale, as many other people do. In Christ, we speak as men of sincerity, as envoys of God and in God's presence.

#### New English Bible

At least we do not go hawking the word of God about, as so many do; when we declare the word we do it in sincerity, as from God and in God's sight, as members of Christ.



## 2 THESSALONIANS 2:7 CT (A.D. 54)

"THE MYSTERY OF-THE LAWLESSNESS IS ALREADY OPERATING FOR ITSELF."

HOW SERIOUS IS THIS OPERATION OF THE SLANDERER, NAMELY THE SERPENT?

THE INTERLINEAR LITERAL TRANSLATION OF THE GREEK NEW TESTAMENT(KJ)

4. Without some knowledge of Hebrew and Greek, you cannot be certain, in a single instance, that in your sermon based on a Scripture text, you are presenting the correct teaching of that text.

5. Without some knowledge of Hebrew and Greek, you cannot be an independent student, or a reliable interpreter of the word of God. (By George Ricker Berry, Ph.D.)

THE FOLLOWING FROM AN ARTICLE IN THE OCALA STAR-BANNER OCT.6,1990.

More than 50 Bible translations have been issued since 1952.

"All Bible translators are thieves. We all steal from one another. But you have to know what to take." Prof. Orlinsky.

"ADULTERATING THE WORD OF GOD FOR FILTHY LUCRE" (PAGE 10).

**13 But evil MEN and γόντες will-progress on the worse,  
leading-astray and being-led-astray. II TIMOTHY 3 CT**

See page 2, Apologetics 6, Teaching Dictionary pages 323, 238.

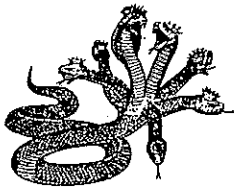

# The Dragon

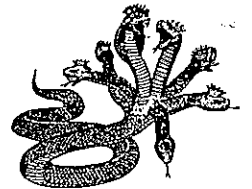

THE ADVERSARY AS THE DRAGON HAS SLOWLY BUT SURELY BEEN EXTENDING HIS POWER. FIRST IN EGYPT. NEXT IN ASSYRIA. THEN IN BABYLON. NEXT IN MEDO-PERSIA. IN THE FIFTH WORLD POWER HE BECAME KNOWN AS ZEUS. DANIEL SAID THIS POWER WAS TO "BEAR RULE OVER ALL THE EARTH." (DAN. 2:39, DISCOURSE 7 PAGE 2.)

In the days of Jesus his authority was established in Rome. The adversary offered this authority to Jesus. (Luke 4:6 page 5). He later made this offer to Mohammed through one of his angels. THE LIBRARY OF UNIVERSAL HISTORY, by Clare says "Thus Mohammed yielded to the temptation which Christ resisted." (Discourse 5, page 42).

Further, "--- no impostor, civil or religious, could ever succeed in establishing a permanent influence over the minds of millions of the human race." The Moslems now number more than 1,000,000,000.

There are many Bible references to God's angels appearing on the earth. What happened to the adversary's angels that were cast out of heaven with him? God's angels and the adversary's angels were at one time of the same heavenly creation. If God's angels appear to men, why should the adversary's angels not likewise be appearing to men? They do appear, but the adversary presents his angelic forces in a very "hidden" and confused manner. The dragon uses his angels to operate, under his authority, for the control of world powers. His angels are referred to as "geniuses" or "demons". Refer to Discourse 5 and pages 38 and 25.



HESIOD SPEAKS OF DEMONS, AND SAYS THAT THEY WERE 30,000 IN NUMBER, AND THAT THEY DWELLED ON EARTH UNSEEN BY MORTALS, AS THE MINISTERS OF ZEUS. ✱

The Midrash Rabbah refers to male and female demons in Numbers page 420, destroying demons in Numbers page 815, and thousands of demons in Deuteronomy page 92.

ROMAN EMPIRE BEGAN, B.C.31.  
OCTAVIUS CAESAR SOLE MASTER  
OF THE ROMAN WORLD. TITLED  
AUGUSTUS (THE DIVINE), B.C.27.  
PONTIFEX MAXIMUS, B.C. 12.  
SUPREME IN ALL RELIGIOUS  
AFFAIRS.

Dictionary of Greek and Roman  
Biography & Mythology, Smith.

► GENIUS, a protecting spirit, analogous to the guardian angels invoked by the Church of Rome. The belief in such spirits existed both in Greece and at Rome. The Greeks called them δαίμονες, daemons, and appear to have believed in them from the earliest times, though Homer does not mention them. Hesiod (*Op. et Dies*, 235) speaks of δαίμονες, and says that they were 30,000 in number, and that they dwelled on earth unseen by mortals, as the ministers of Zeus. ✱

The daemons are further described as the ministers and companions of the gods,

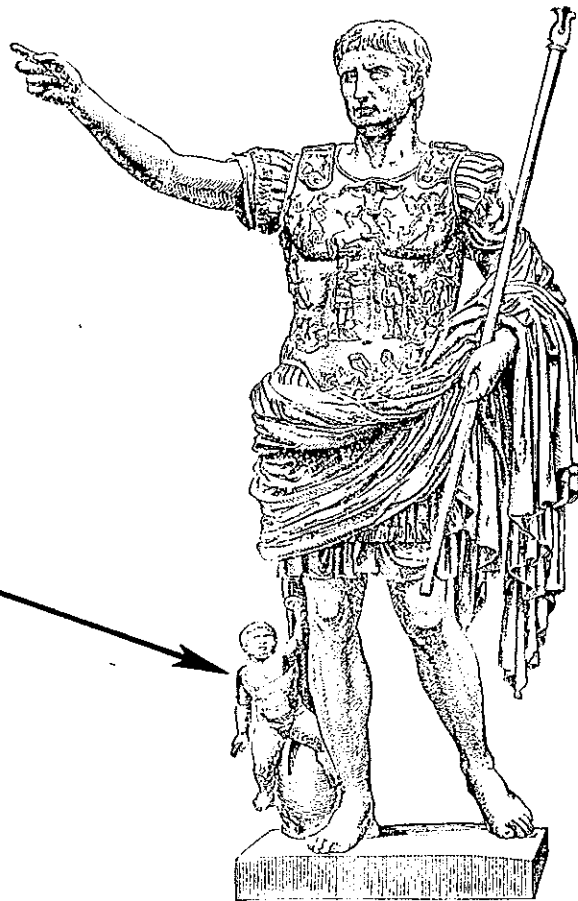

The solidus (above, right), its reverse showing Victory writing vot xx on a shield held by a genius, was struck to commemorate Constantine's 20th year in power. A genius was thought to be a spirit who watched over each man and was largely responsible for his lot in life. A similar figure was used centuries later on coins of France to represent the genius of the nation writing a new constitution at the time of the French Revolution (see page 149).



Napoleon III's disastrous defeat in the Franco-Prussian War of 1870 led to the Third Republic which lasted until World War II. For its coin designs, the new Republic at first turned to a design used during the First Republic, an angel or genius writing the word CONSTITUTION on a tablet.

# (SATAN'S) ZEUS'S ANGELS ?30,000?



IN IDOLATRY THESE ANGELS WERE CALLED "AGATHODAIMONS", GOOD DEMONS.

Caesar Augustus had his Genius. (page 12). Zeus ruled the Roman Empire, where Caesar Augustus was supreme in all religious affairs having the title PONTIFEX MAXIMUS, chief bridge-builder. (page 12) Jesus was born during his reign. When Jesus secured victory at the cross, Zeus attacked the Christians through 10 periods of trial.

DANIEL 7:7

REVELATION 2 CT

BABYLON.  
APOLOGETICS  
22 23 24



10 You-be not fearing things-which you-are-about to-be-suffering. Behold the slanderer is-about to-be-casting some out-of YOU into a guard-house in-order-that YOU-might-be-tried, and YOU-will-have tribulation of ten days. You-be-becoming trustworthy unto death, and I-shall-give to-you the crown of-the life.  
11 The *one* having an ear let-him-hear what the Spirit is-saying to-the assemblies. The *one* having-victory by no means might-he-be-done-harm out-of the death *namely*-the second.

These tribulations were further signified by the 10 horns of Daniel 7:7. (See Apologetics 22). When Zeus, failed to stop the preaching of the gospel, he decided to join the "church" and run the operation. To this end he chose Constantine as the means to enter the "church", giving him the title **PONTIFEX MAXIMUS**.

Britannica, Vol.26,p.924

Christianity as the state religion. The Edict of Milan, a cluster of documents issued by Constantine the Great in 313, made Christianity a lawful religion; by the end of the 4th century it had become the state religion. Historians call the church of this period the Constantinian church, designating the privileged position of the church within the state.

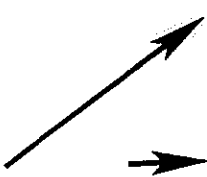

The early Middle Ages, especially from the 4th to the 7th century, were the ages of the great ecumenical, or general, councils. It was no doubt the new "Roman" character of the Constantinian church that led Christians to look for an expression of the voice of the whole church, the *katholikē*, that would be the voice of the whole world, the *oikoumenē*, just as the emperor was the voice of secular authority for the whole world.

WOULD YOU BUILD TEMPLES TO A NONEXISTENT GOD? ROME ITSELF HAD 420 SUCH TEMPLES. IN 325 A.D. CONSTANTINE CALLED THE COUNCIL OF NICAEA. AS PONTIFEX MAXIMUS HE WAS LEADER OF THE PAGAN IDOLATRY. HE IS SAID TO HAVE HAD A VISION OF APOLLO AT A SHRINE IN GAUL. SEE APOLOGETICS 23, PAGE 2.

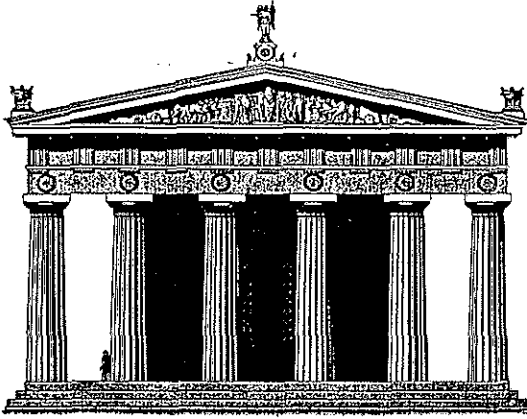

JUPITER AT OLYMPIA

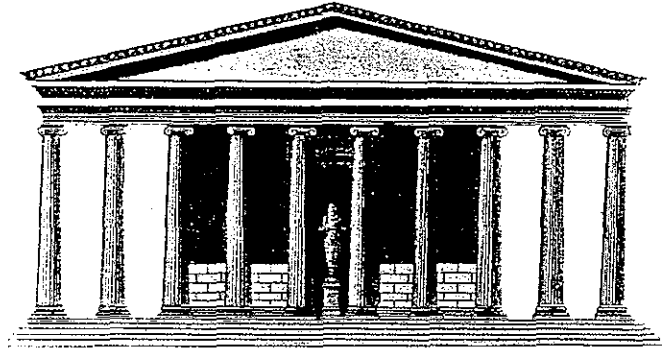

DIANA AT EPHEBUS

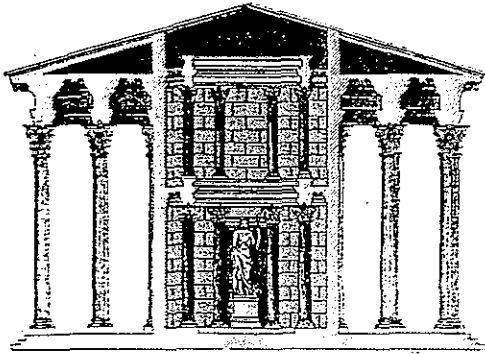

JUPITER IN ATHENS

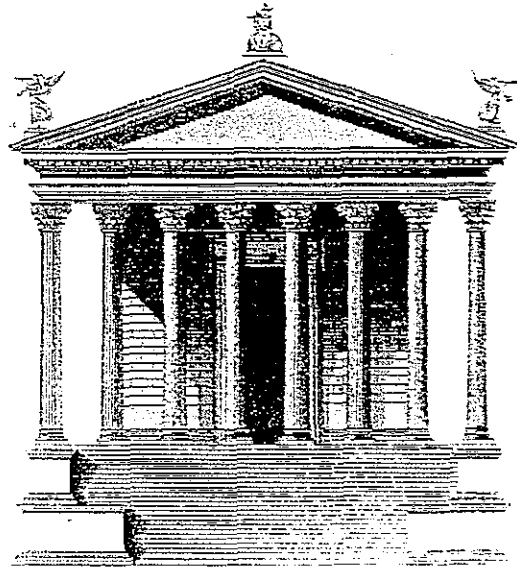

CASTOR AND POLLUX AT ROME

ROMAN EMPEROR THEODOSIUS I DECLARED CHRISTIANITY THE STATE RELIGION. (FEB.27,380A.D.) THEODOSIUS ISSUED AN EDICT POSITIVELY FORBIDDING ANY AND ALL PAGAN CEREMONIES ON PENALTY OF DEATH, AND CLOSED ALL THE HEATHEN TEMPLES AND CONFISCATED THEIR ENDOWMENTS. THEODOSIUS THE GREAT WAS THE LAST EMPEROR WHO REIGNED OVER THE WHOLE ROMAN DOMINIONS. HE DIED A.D. 395. POPE LEO I TOOK THE TITLE PONTIFEX MAXIMUS.



Pallas-Athene of the Greeks

Diana of the Ephesians



Zeus or Jupiter



Would you make statues of "little red riding hood" or "snow-white" and then talk to them or even pray to them?



THE ROMAN EMPIRE HAD NOW ENTERED THE CHURCH, THAT IS, THE ROMAN CHURCH. THE LATIN LANGUAGE IS STILL USED. GREAT CATHEDRALS WERE BUILT. IMAGES WERE MADE TO WHICH PRAYERS ARE OFFERED. ZEUS HAD MOVED HIS AUTHORITY INTO THE SEVENTH WORLD POWER, WHICH HE HAD DEVELOPED. THE WORD CATHOLIC WAS ADDED TO ROMAN. THE CATHOLIC CHURCH WAS TO BE UNIVERSAL (oikoumene), THAT IS, ECUMENICAL. IT WAS TO SPEAK FOR THE WHOLE WORLD. ZEUS'S AUTHORITY IS LIMITED TO THE SEVENTH WORLD POWER. OIKOUMENE DOES NOT MEAN WORLD, BUT THE INHABITED-EARTH. WHILE THERE ARE NO PHYSICAL BOUNDARIES, THERE IS A LIMIT FIXED BY IT'S NAME, THE ROMAN ECUMENICAL ASSEMBLY.

## HALLEY'S BIBLE HANDBOOK 760

### Paganization of the Church

Emperor Constantine (A.D. 306-337), when he became a Christian, issued an Edict granting Everybody the right to choose his own Religion.

Emperor Theodosius (A.D. 378-398), made Christianity the State Religion of the Roman Empire, and made Church Membership Compulsory. This was the Worst Calamity that has ever befallen the Church. This Forced Conversion filled the Churches with Unregenerate People.

Not only so, Theodosius undertook the Forcible Suppression of all other Religions, and Prohibited Idol Worship. Under his decrees, Heathen Temples were torn down by mobs of Christians, and there was much bloodshed.

Christ had designed to conquer by purely Spiritual and Moral Means. Up to this time Conversion was Voluntary, a Genuine Change in Heart and Life.

But now the Military Spirit of Imperial Rome had entered the Church. The Church had Conquered the Roman Empire. But in reality the Roman Empire had Conquered the Church, by Making the Church over into the Image of the Roman Empire.

The Church had Changed its Nature, had entered its Great Apostasy, had become a Political Organization in the Spirit and Pattern of Imperial Rome, and took its Nose-Dive into the millennium of Papal Abominations.

The Imperial Church of the 4th and 5th centuries had become an entirely different institution from the persecuted church of the first three centuries. In its ambition to Rule it lost and forgot the spirit of Christ.

Worship, at first very simple, was developed into elaborate, stately, imposing ceremonies having all the outward splendor that had belonged to heathen temples.

Ministers became Priests. The term "priest" was not applied to Christian ministers before A.D. 200. It was borrowed from the Jewish system, and from the example of heathen priesthood. Leo I (440-61) prohibited priests from marrying, and Celibacy of priests became a law of the Roman Church.

Conversion of the Barbarians. The Goths, Vandals and Huns who overthrew the Roman Empire accepted Christianity; but to a large extent their conversion was nominal and this further filled the Church with Pagan practices.

Conflicts with Heathen Philosophies. Even as every generation seeks to interpret Christ in terms of its own thinking, so, no sooner had Christianity made its appearance than it began its process of amalgamation with Greek and Oriental Philosophies; and there arose many Sects: Gnosticism, Manichaeism, Montanism, Monarchianism, Arianism, Apollinarianism, Nestorianism, Eutychianism, Monophysites. From the 2nd to the 6th centuries the Church was rent with controversies over these and similar Isms, and almost lost sight of its true mission.

### Notre Dame, Our Lady

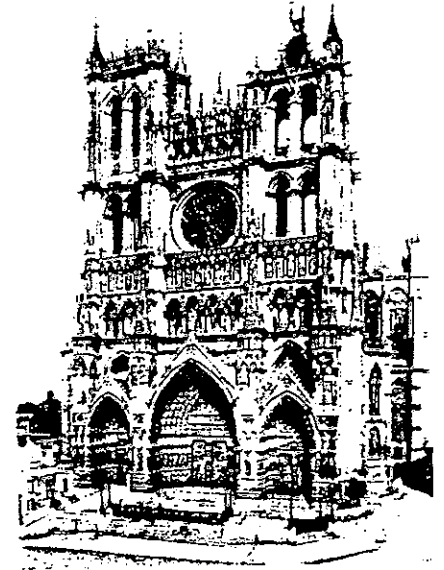

A TEMPLE TO A GODDESS

THE POPE PRAYS TO WHOM THE STATUE REPRESENTS. SO DID THE ROMANS.



Pope John Paul II in the hospital recovering from several serious gunshot wounds thanks Our Lady of Fatima for saving his life. He recognized in this assassination attempt on his life, and Our Lady's miraculous interceded and appeal from Her to listen to Her Fatima Message.

THE SEVENTH WORLD POWER WAS ESTABLISHED. THE COUNCIL OF EPHEBUS 431 A.D. DECIDED THAT MARY WAS THE MOTHER OF GOD. POPE LEO (440-461 A.D.) TOOK THE TITLE PONTIFEX MAXIMUS, "CHIEF BRIDGE-BUILDER". UNDER POPE FELIX IV (526-530 A.D.) PAGAN TEMPLES WERE CONVERTED FOR "CHRISTIAN" WORSHIP. (APOLOGETICS 33). UNDER POPE BONIFACE IV (608-615 A.D.) THE GREAT ROMAN PANTHEON, ONCE DEDICATED TO ALL THE GODS, WAS NOW DEDICATED TO THE BLESSED VIRGIN MARY AND THE MARTYRS.

ZEUS FELT SECURE ENOUGH TO START THE EIGHTH WORLD POWER. AN ANGEL, CALLED GABRIEL, APPEARED TO MOHAMMED. (SEE PAGE 11). THE HEGIRA (622 A.D.) IS THE POINT FROM WHICH MOHAMMEDANS RECKON TIME. (SEE DISCOURSE 5, PAGE 42).

HISTORY OF THE WORLD, Wright, p.366.

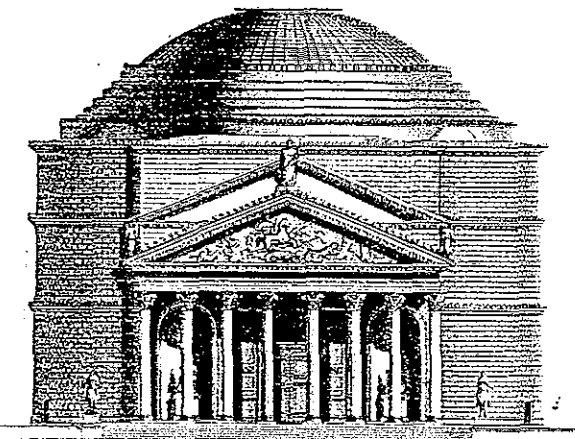

THE ROMAN PANTHEON

ROMANISM AS IT IS, Barnum, p.57

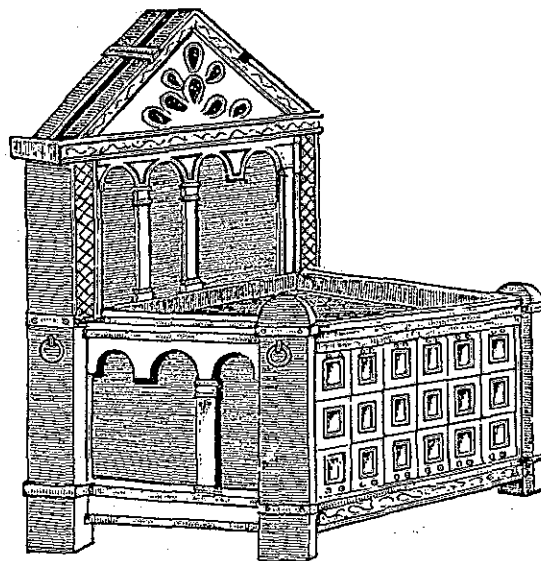

CHAIR OF ST. PETER IN THE VATICAN. ENGRAVED WITH THE EXPLOITS OF HERCULES, SON OF ZEUS.



THE MAJOR CONTROLLER OF WORLD POWER.



LEAVING THE DISCUSSION OF WORLD POLITICAL POWER, LET US RETURN TO REVELATION CHAPTER 12. WE NEED NOW TO CONSIDER THE 'FIRST SIGN.

THE EXPLANATION OF THE WOMAN WILL DEPEND ON THE UNDERSTANDING IN REGARDS AS TO WHOM THE CHILD IS. THE ADVERSARY'S MINISTERS IN THE "CHURCH" HAVE PLANTED A GREAT DEAL OF ANTISEMITISM IN THE BIBLE COMMENTARIES AND VARIOUS OTHER WRITINGS. FOLLOWING IS ONE STRIKING EXAMPLE.

HOLY BIBLE, Confraternity Edition, 1950.  
Footnote on Revelation 12, page 337.

MARY Our Sweet Mother  
Society of Saint Paul, 1950

Chap. 12, Ver. 1. A woman: this woman is not the Blessed Virgin, for the details of the prophecy do not fit her. The prophecy pictures the Church of the Old and New Covenants. The beams of the divine glory clothe her; the moon is beneath her feet; she is crowned with a crown of twelve stars, and she must bring forth Christ to the world. By accommodation the Church applies this verse to the Blessed Virgin.



REVELATION 12 CT

1 And a great sign was-seen in the heaven, a woman having-been-and-still-cast-around *with* the sun, and the moon underneath her feet and on her head a crown of-stars twelve,  
 2 And having in her womb, and suffering-birth-pains she-is-crying and being-tormented to-bring-forth.  
 3 And another sign was-seen in the heaven, and behold, a great dragon red-as-fire, having seven heads and ten horns and on his heads seven diadems,  
 4 And his tail is-dragging the third of-the stars of-the heaven, and he-cast them into the earth. And the dragon has-stood-and-still-stands in-sight of-the woman namely-the future one to-bring-forth, in-order-that at-the-time-that she-might-bring-forth he-might-devour her child.  
 A 5 And she-brought-forth a son, a male, who is-about to-be-shepherding all the Gentiles with an iron rod; and her child was-seized to the God and to his throne.



Make believe you are John. There are two births, A&B. A, is in time before John. B, sometime in the future.

BIRTH "A" IS WELL ESTABLISHED BY JOHN HIMSELF IN REV.19:15. ONCE REV.12:5 IS UNDERSTOOD AS THE BIRTH OF JESUS, THE WOMAN, REV.12:1 WILL BE EASILY IDENTIFIED AS THE NATION OF ISRAEL.

REVELATION 19 CT

11 And I-saw the heaven having-been-and-still-opened, and behold, a white horse, and the one sitting on it being-called trustworthy and authentic, and in justice he-is-judging and he-is-warring.  
 12 But his eyes as a flame of-fire, and on his head many diadems, having a name having-been-and-still-written which not-one is-knowing-absolutely unless himself,  
 13 And having-been-and-still-cast-around *with* a garment having-been-and-still-dipped in-blood, and his name has-been-and-is-still-called The Word of The God.  
 14 And the armies, namely-the ones in the heaven, were-following him on white horses, having-been-and-still-clothed-in fine-linen white and clean.  
 15 And out-of his mouth a sharp sword is-proceeding-out, in-order-that with it he-might-smite the Gentiles; and he himself will-shepherd them with a rod of-iron; and he himself is-treading the wine-press of-the wine, namely-of-the anger, and of-the wrath of-the God namely-the Almighty.

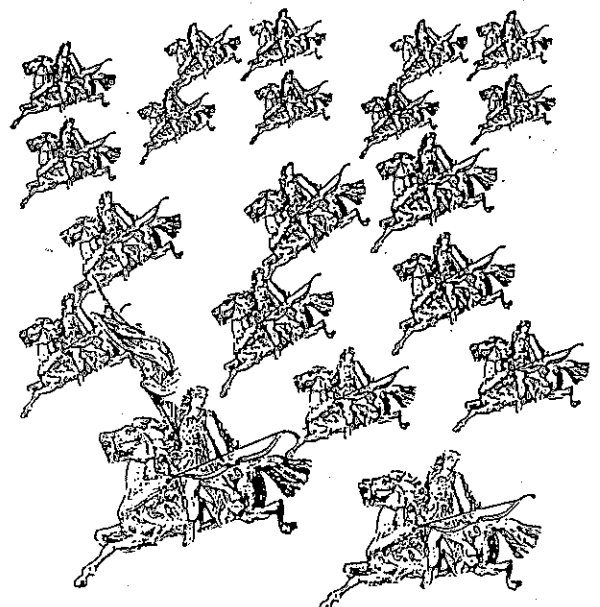



THE WOMAN, ISRAEL, IS IDENTIFIED BY GENESIS 37:9,10. JESUS WAS BROUGHT-FORTH INTO A JEWISH FAMILY BY A JEWISH MAID MARY. TO MAKE THIS "SIGN" OTHER THAN ISRAEL IS FALSE. WE NEED TO GO BACK IN HISTORY TO ABRAHAM. WE WILL RETURN TO BIRTH "B" LATER.

GOD'S PROMISE TO ABRAHAM  
GENESIS 15:5,6.

★ 5 And he brought him forth abroad, and said, Look now toward heaven, and number the stars, if thou be able to number them: and he said unto him, So shall thy seed be. 6 And he believed in Jehovah; and he reckoned it to him for righteousness.

ONLY 11 STARS ARE IN THIS DREAM, JOSEPH IS THE 12TH. GEN.37:9,10.

★ 9 And he dreamed yet another dream, and told it to his brethren, and said, Behold, I have dreamed yet a dream; and, behold, the sun and the moon and eleven stars made obeisance to me. 10 And he told it to his father, and to his brethren; and his father rebuked him, and said unto him, What is this dream that thou hast dreamed? Shall I and thy mother and thy brethren indeed come to bow down ourselves to thee to the earth?

BECAUSE OF ABRAHAM, ISAAC, AND JACOB GOD CHOSE ISRAEL TO BE HIS OWN POSSESSION ABOVE ALL PEOPLES THAT ARE ON THE FACE OF THE EARTH. JEHOVAH CALLED ISRAEL HIS SON. FOR THIS REASON JESUS TOLD THE JEWS TO PRAY, "OUR FATHER WHO ART IN HEAVEN, HALLOWED BE THY NAME." (MATTHEW 6:9). JESUS DID NOT TEACH THIS PRAYER TO GENTILES. THE JEWS, IN FIGURE, ARE REFERRED TO AS THE STARS. ★ ANTISEMITISM BEGAN A LONG TIME AGO; NOT THAT PEOPLE HATE THE JEWS, THEY HATE THE GOD OF THE JEWS.

DANIEL 8:9,10

★ 9 And out of one of them came forth a little horn, which waxed exceeding great, toward the south, and toward the east, and toward the glorious land. 10 And it waxed great, even to the host of heaven; and some of the host and of the stars it cast down to the ground, and trampled upon them.

★ THE DRAGON "IS-DRAGGING", THE THIRD OF THE STARS OF THE HEAVEN, IN THE DAY OF JOHN'S WRITING. THE DRAGON IS ALWAYS ANTI-SEMITIC. HE SAID, "I WILL EXALT MY THRONE ABOVE THE STARS OF GOD". (PAGE 8).

THE ZODIAC IS ISRAEL'S GUARANTEE.  
JEREMIAH 31:35,36

★ 35 Thus saith Jehovah, who giveth the sun for a light by day, and the ordinances of the moon and of the stars for a light by night, who stirreth up the sea, so that the waves thereof roar; Jehovah of hosts is his name: 36 If these ordinances depart from before me, saith Jehovah, then the seed of Israel also shall cease from being a nation before me for ever.

DEUTERONOMY 7:6

★ 6 For thou art a holy people unto Jehovah thy God: Jehovah thy God hath chosen thee to be a people for his own possession, above all peoples that are upon the face of the earth.

HOSEA 11:1

11 When Israel was a child, then I loved him, and called my son out of Egypt.

REVELATION 12 CT

3 And another sign was-seen in the heaven, and behold, a great dragon red-as-fire, having seven heads and ten horns and on his heads seven diadems, ★ 4 And his tail is-dragging the third of the stars of the heaven, and he-cast them into the earth. And the dragon has-stood-and-still-stands in-sight of the woman namely-the future one to-bring-forth, in-order-that at-the-time-that she-might-bring-forth he-might-devour her child.

WITH THE ESTABLISHMENT OF THE STATE OF ISRAEL THE CONFLICT FOR THE STARS HAS BEEN BROUGHT INTO PLAIN VIEW. THE ADVERSARY BY WHATEVER NAME YOU WISH TO CALL HIM; SATAN, DEVIL, ZEUS OR JUPITER, HE IS VERY REAL. HERE ARE TWO PIECES OF EVIDENCE THAT PROVE THERE IS A VERY REAL CONFLICT.

## JUPITER

MYSTERY RELIGIONS IN THE  
IN THE ANCIENT WORLD  
JOSCELYN GODWIN

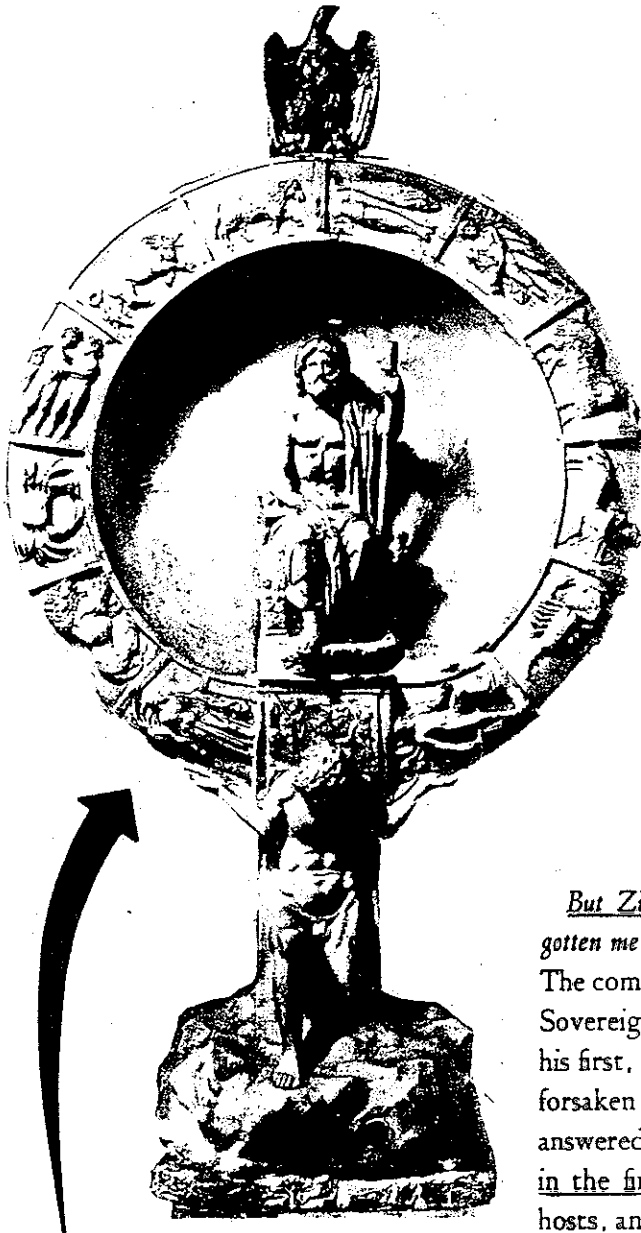

Jupiter in the Zodiac  
Second century A.D.  
Vatican Museum.

## JEHOVAH

ISRAELI POSTAGE STAMPS  
February 27, 1961  
Constellations of the  
Zodiac.



### THE BABYLONIAN TALMUD BERAKOTH 32b

*But Zion said, The Lord hath forsaken me, and the Lord hath forgotten me.*<sup>2</sup> Is not 'forsaken' the same as 'forgotten'? Resh Lakish said: The community of Israel said before the Holy One, blessed be He: Sovereign of the Universe, when a man takes a second wife after his first, he still remembers the deeds of the first. Thou hast both forsaken me and forgotten me! The Holy One, blessed be He, answered her: My daughter, twelve constellations have I created in the firmament, and for each constellation I have created thirty hosts, and for each host I have created thirty legions, and for each legion I have created thirty cohorts, and for each cohort I have created thirty maniples, and for each maniple I have created thirty camps, and to each camp I have attached three hundred and sixty-five thousands of myriads of stars, corresponding to the days of the solar year, and all of them I have created only for thy sake, and thou sayest, Thou hast forgotten me and forsaken me!

CONSIDER ANOTHER VERY IMPORTANT FACT OFTEN IN THE NEWS. GOD DOES NOT ONLY HAVE A CHOSEN PEOPLE, BUT HE ALSO HAS A CHOSEN LAND IN WHICH ABRAHAM, ISAAC, AND JACOB WILL LIVE.

GOD'S CALL OF ABRAM.  
FIRST PROMISE OF LAND.  
Genesis 12:1-7

**12** Now <sup>1</sup>Jehovah said unto Abram, Get thee out of thy country, and from thy kindred, and from thy father's house, unto the land that I will show thee: <sup>2</sup> and <sup>m</sup>I will make of thee a great nation, and <sup>n</sup>I will bless thee, and make thy name great; and <sup>o</sup>be thou a blessing: <sup>3</sup> and <sup>p</sup>I will bless them that bless thee, and him that curseth thee will I curse: <sup>q</sup>and in thee shall all the families of the earth be blessed.

And the Canaanite was then in the land. <sup>7</sup> And Jehovah <sup>r</sup>appeared unto Abram, and said, <sup>s</sup>Unto thy seed will I give this land: and there builded he <sup>v</sup>an altar unto Jehovah, who appeared unto him.

ABRAM VISITS THE LAND.  
Genesis 13:14-18

<sup>14</sup> And Jehovah said unto Abram, after that Lot was separated from him, <sup>2</sup>Lift up now thine eyes, and look from the place where thou art, northward and southward and eastward and westward: <sup>15</sup> <sup>a</sup>for all the land which thou seest, <sup>b</sup>to thee will I give it, and to thy seed for ever. <sup>16</sup> And I will make thy seed <sup>c</sup>as the dust of the earth: so that if a man can number the dust of the earth, then may thy seed also be numbered. <sup>17</sup> Arise, <sup>d</sup>walk through the land in the length of it and in the breadth of it; for <sup>e</sup>unto thee will I give it. <sup>18</sup> And Abram moved his tent, and came and dwelt by the <sup>2</sup>oaks of <sup>f</sup>Mamre, which are in Hebron, and built there <sup>g</sup>an altar unto Jehovah.

NUMBERS 1, 2, 3 MAKE IT PLAIN THAT ISRAELIS ARE THE SOJOURNERS WITH GOD, NOT THE ARABS.

SCRIPTURE DOES NOT TELL US WHERE ABRAM WALKED TO VIEW THE LAND. A RECORD OF ABRAM'S LONG WALK WAS FOUND AMONG THE DEAD SEA SCROLLS FOUND IN ISRAEL BEGINNING IN 1947.

THE LAND DESCRIBED.  
Genesis 15:18-21

<sup>18</sup> In that day Jehovah made a covenant with Abram, saying, Unto thy seed have I given this land, from <sup>1</sup>the river of Egypt unto the great river, the river Euphrates: <sup>19</sup> <sup>1</sup>the Kenite, and the Kenizzite, and the Kadmonite, <sup>20</sup> and the Hittite, and the Perizzite, and the Rephaim, <sup>21</sup> and the Amorite, and the Canaanite, and the Girgashite, and the Jebusite.

THE LAND GRANT CONTINUES  
TO JACOB. Genesis 35:9-12

<sup>9</sup> And God appeared unto Jacob again, when he came from Paddan-aram, and <sup>o</sup>blessed him. <sup>10</sup> And <sup>h</sup>God said unto him, Thy name is Jacob: thy name shall not be called any more Jacob, but Israel shall be thy name: and he called his name Israel. <sup>11</sup> And God said unto him, I am <sup>4</sup>God Almighty: <sup>k</sup>be fruitful and multiply; a nation and a <sup>l</sup>company of nations shall be of thee, and <sup>m</sup>kings shall come out of thy loins; <sup>12</sup> and <sup>n</sup>the land which I gave unto Abraham and Isaac, to thee I will give it, and to thy seed after thee will I give the land.

"THE LAND IS MINE."  
Leviticus 25:23

<sup>23</sup> And the land shall not be sold in perpetuity; for <sup>b</sup>the land is mine: for <sup>c</sup>ye are strangers and sojourners with me.

ACTS 7 CT.

<sup>4</sup> Then having-gone-out, out-of *the* land of Chaldaeans he-resided in Charran. And-thence after his father died-off he-resettled him into this land into which YOU yourselves-are residing now,

<sup>5</sup> And he-gave not to-him inheritance in it neither a foot's rostrum, and he-promised to-give to-him with-reference-to a holding it down and to his seed after him, while not being to-him a child.

4



Bukhara • Samarkand

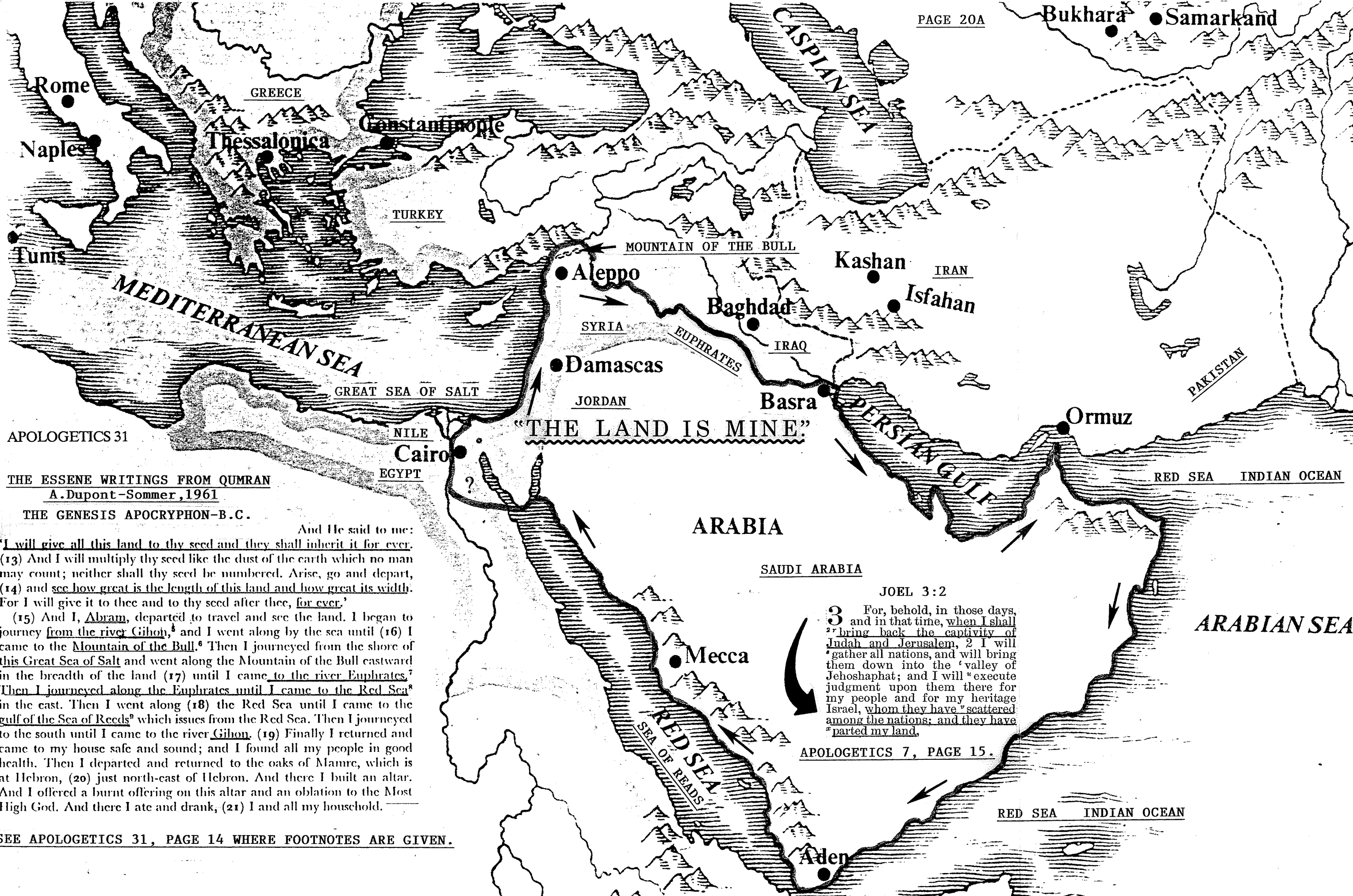

APOLOGETICS 31

THE ESSENE WRITINGS FROM QUMRAN  
A. Dupont-Sommer, 1961

THE GENESIS APOCRYPHON-B.C.

And He said to me:

'I will give all this land to thy seed and they shall inherit it for ever.  
 (13) And I will multiply thy seed like the dust of the earth which no man may count; neither shall thy seed be numbered. Arise, go and depart,  
 (14) and see how great is the length of this land and how great its width. For I will give it to thee and to thy seed after thee, for ever.'

(15) And I, Abram, departed to travel and see the land. I began to journey from the river Gihon,<sup>4</sup> and I went along by the sea until (16) I came to the Mountain of the Bull.<sup>6</sup> Then I journeyed from the shore of this Great Sea of Salt and went along the Mountain of the Bull eastward in the breadth of the land (17) until I came to the river Euphrates.<sup>7</sup> Then I journeyed along the Euphrates until I came to the Red Sea.<sup>8</sup> in the east. Then I went along (18) the Red Sea until I came to the gulf of the Sea of Reeds<sup>9</sup> which issues from the Red Sea. Then I journeyed to the south until I came to the river Gihon. (19) Finally I returned and came to my house safe and sound; and I found all my people in good health. Then I departed and returned to the oaks of Mamre, which is at Hebron, (20) just north-east of Hebron. And there I built an altar. And I offered a burnt offering on this altar and an oblation to the Most High God. And there I ate and drank, (21) I and all my household.

"THE LAND IS MINE"

ARABIA

SAUDI ARABIA

JOEL 3:2

3 For, behold, in those days, and in that time, when I shall <sup>1</sup>bring back the captivity of Judah and Jerusalem, <sup>2</sup>I will gather all nations, and will bring them down into the valley of Jehoshaphat; and I will execute judgment upon them there for my people and for my heritage Israel, whom they have scattered among the nations; and they have parted my land.

APOLOGETICS 7, PAGE 15.

SEE APOLOGETICS 31, PAGE 14 WHERE FOOTNOTES ARE GIVEN.

EVEN THOUGH THE ADVERSARY HAD CAST DOWN ONE THIRD OF THE STARS (REV.12:4 AND PAGE 18) HE WAS NOT SATISFIED. HE HAD SOME SUCCESS DURING OLD TESTAMENT HISTORY. THE DRAGON CONTINUED TO STAND IN SIGHT OF THE WOMAN, ISRAEL. HE KNEW THAT ISRAEL WOULD ONE DAY BE "BROUGHT FORTH" A FULFILLMENT OF ALL OF GOD'S PROMISES, AND THIS EVENT HE PURPOSED TO DEFEAT AT ALL COSTS.

BUT GOD THE SON, CAME INTO THE WORLD IN A BODY OF FLESH. (REV.12:5). IN THIS BODY OF FLESH HE SATISFIED ALL OF THE THINGS NECESSARY; NOT ONLY TO REDEEM ISRAEL, BUT TO PAY FOR THE SINS OF THE WHOLE WORLD.

JOHN 1 CT

τετέλεσται

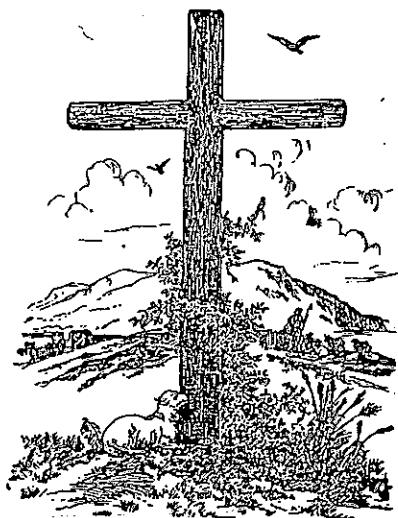

1 The Word was in *the* beginning, and the Word was with the God, and the Word was God.

14 And the Word came-to-be flesh, and he-tabernacled among us, and we-beheld his glory, glory as of-*an* only-be-gotten from *the* Father full of-favor and truth.

THE 7TH SAYING FROM THE CROSS WAS JUST ONE WORD IN GREEK.

TETELESTAI

"IT-HAS-BEEN-AND-IS-FINISHED": RECEIPTS HAVE BEEN FOUND WITH TETELESTAI, "PAID IN FULL."

JOHN 19 CT

30 When therefore the Jesus took the sour-wine he-said: It-has-been-and-is-finished; and having-reclined the head he-gave-over the spirit.

I JOHN 2 CT

2 And he himself is *a* propitiation concerning our sins, but not concerning ours only BUT also concerning the total world.

Jesus was taken up to the Father. (Rev. 12:5)

JESUS HAD WARNED ISRAEL OF THINGS TO COME BOTH IN PARABLES AND DIRECT STATEMENTS DURING HIS EARTHLY MINISTRY. THE ADVERSARY, WITH ALL HIS WELL PLACED MINISTERS IN THE "CHURCH", HAS HIDDEN MANY OF THESE PROPHECIES BY CORRUPTING THE TRANSLATORS FOR HIS PURPOSE. FIRST, CONSIDER SOME DIRECT STATEMENTS.

## JESUS WARNS ISRAEL OF UNINTERRUPTED ANTISEMITISM

MATTHEW 24 CT

9 Then they-will-give YOU over into tribulation, and they-will-kill YOU; and YOU-will-be being-hated by all the Gentiles because-of my name.

There are some very important facts contained in the Consistent Translation. YOU, when in capitals, is plural. This fact is usually not discernible when "you" is printed with small letters. The phrase, "will-be being-hated" is a periphrastic future. That is, it is going on continuously. The third thing to be aware of, is that Jesus is speaking to Jews, not Gentiles. There are only two groups of people in the world, Jews and Gentiles. There are no "Christians" at present because these statements are made before the cross. Note and compare the following 8 translations and see how the adversary has hidden truth.

**King James Version**

9 Then shall they deliver you up to be afflicted, and shall kill you: and ye shall be hated of all nations for my name's sake.

**Living Bible**

9 "Then you will be tortured and killed and hated all over the world because you are mine,

**Today's English Version**

9 "Then you will be arrested and handed over to be punished, and be put to death. All mankind will hate you because of me.

**New International Version**

9 "Then you will be handed over to be persecuted and put to death, and you will be hated by all nations because of me.

**ALFORD'S GREEK TESTAMENT**

9—13.] τότε, at this time,—during this period, not 'after these things have happened.'

Do not think that "then" means "after", that will contradict Luke 21.

70 A.D.

1991 A.D. ?



FOLLOWING IS AN EXAMPLE OF WHAT TRANSLATORS HAVE DONE WITH A VERY SHORT PARABLE. JESUS WAS SPEAKING TO "CROWDS", NOT "MULTITUDES" AS IN THE KING JAMES. THE 7 OTHER OF OUR SAMPLE TRANSLATIONS USE "CROWDS". SEE SYNONYMS OF THE NEW TESTAMENT, BY TRENCH, PAGE 344.

**MATTHEW 13 CT**

34 The Jesus spoke all these-things in parables to-the crowds, and separate-from parable he-was not speaking to-them;

**King James Version**

13 Ye are the salt of the earth: but if the salt have lost his savour, wherewith shall it be salted? It is thenceforth good for nothing, but to be cast out, and to be trodden under foot of men.

**Living Bible**

13 "You are the world's seasoning, to make it tolerable. If you lose your flavor, what will happen to the world? And you yourselves will be thrown out and trampled underfoot as worthless.

**Today's English Version**

13 "You are like salt for all mankind. But if salt loses its taste, there is no way to make it salty again. It has become worthless, so it is thrown away and people walk on it.

**New International Version**

13 "You are the salt of the earth. But if the salt loses its saltiness, how can it be made salty again? It is no longer good for anything, except to be thrown out and trampled by men.

**MATTHEW 24:9****Phillips Modern English**

For then comes the time when men will hand you over to persecution, and kill you. And all nations will hate you because you bear my name.

**Revised Standard Version**

9 "Then they will deliver you up to tribulation, and put you to death; and you will be hated by all nations for my name's sake.

**Jerusalem Bible**

9 "Then they will hand you over to be tortured and put to death; and you will be hated by all the nations on account of my name.

**New English Bible**

"You will then be handed over for punishment and execution; and men of all nations will hate you for your allegiance to me.

**LUKE 21 CT**

12 But before quite-all these-things they-will-cast-on upon YOU their hands, and they-will-persecute, giving-over into synagogues and guard-houses, being-led upon kings and governors on-account-of my name.

17 And YOU-will-be being-hated by all because-of my name.

**MATTHEW 5:13****Phillips Modern English**

"You are the earth's salt. But if the salt should become tasteless, what can make it salt again? It is completely useless and can only be thrown out of doors and stamped under foot.

**Revised Standard Version**

13 "You are the salt of the earth; but if salt has lost its taste, how shall its saltiness be restored? It is no longer good for anything except to be thrown out and trodden under foot by men.

**Jerusalem Bible**

13 "You are the salt of the earth. But if salt becomes tasteless, what can make it salty again? It is good for nothing, and can only be thrown out to be trampled underfoot by men.

**New English Bible**

"You are salt to the world. And if salt becomes tasteless, how is its saltiness to be restored? It is now good for nothing but to be thrown away and trodden underfoot.





WHAT DOES MATTHEW 5:13 REALLY SAY? NOT ONE OF THE TRANSLATIONS ON PAGE 22 ARE EVEN CLOSE TO WHAT THE GREEK TEXT SAYS. JESUS WAS TALKING TO JEWS; NOT CHRISTIANS, FOR AT THIS POINT IN HISTORY THERE WERE NO CHRISTIANS. WHEN THIS VERSE IS CORRECTLY TRANSLATED IT SEEMINGLY MAKES NO SENSE.

μωρός, mōros.

ἄφρων, aphrōn.

- Lu. 11:40. (Ye) *fools*, did not he that made
- 12:20. (Thou) *fool*, this night thy soul
- Ro. 2:20. An instructor of the *foolish*, a
- 1Co.15:36. (Thou) *fool*, that which thou sowest
- 2Co.11:16 Let ~~no man~~ think me a *fool* ;
- 2Co.11:16. yet as a *fool* receive me.
  - 19. For ye suffer *fools* gladly, seeing
  - 12: 6. I shall not be a *fool* ; for I
  - 11. I am become a *fool* in glorying ;
- Eph. 5:17. Wherefore be ye not *unwise*,
- 1Pet.2:15. silence the ignorance of *foolish* men

THE CONSISTENT TRANSLATION USES "STUPID" FOR "moros"

- Mat. 5:22. whosoever shall say, Thou *fool*,
- 7:26. shall be likened unto a *foolish* man,
- 23:17. (Ye) *fools* and blind: for whether
- 19. (Ye) *fools* and blind:
- 25: 2. and five (were) *foolish*.
- 3. They that (were) *foolish* took
- 8. the *foolish* said unto the wise,
- 1Co. 1:25. the *foolishness* of God is wiser than men;
- 27. God hath chosen the *foolish* things
- 3:18. let him become a *fool*, that he may
- 4:10. We (are) *fools* for Christ's sake,
- 2Ti. 2:23. *foolish* and unlearned questions avoid,
- Tit. 3: 9. But avoid *foolish* questions,

HERE ARE TWO VERY DIFFERENT GREEK WORDS: aphron and moros. DO YOU BELIEVE THAT GOD USED TWO DIFFERENT WORDS TO MEAN EXACTLY THE SAME THING? DO YOU BELIEVE THAT GOD DIDN'T KNOW THE DIFFERENCE? THE KING JAMES TRANSLATORS MUST HAVE THOUGHT THAT GOD WAS SOMEWHAT CONFUSED. THE SECOND WORD IS THE GREEK WORD FROM WHICH WE GET THE WORD "MORON", "moros". (See the Teaching Dictionary, page 192.) THE CONSISTENT TRANSLATION USES "FOOLISH" TO TRANSLATE THE FIRST WORD, "aphron". COMPARE SOME SCRIPTURES.

WEBSTER'S DICTIONARY

mo·ron \ 'mō(ə)r-än, 'mō(ə)r-\ n [irreg. fr. Gk mōros foolish, stupid; akin to Skt mūra foolish] 1 : a feebleminded person or mental defective with a potential mental age of between eight and twelve years who is capable of doing routine work under supervision 2 : a very stupid person syn see FOOL — mo·ron·ic \mō-'rān-ik, mo-\ adj — mo·ron·i·cal·ly \-i-k(ə)-lē\ adv —

MATTHEW 7 CT

26 And every-one, the-one hearing these my words and doing them not, he-will-be-likened to-a-stupid man, one-who built-up his house upon the sand:

MATTHEW 23 CT

17 Stupid-ones and blind, for which is greater, the gold, or the sanctuary, namely-the-one making the gold holy?

MATTHEW 23 CT

19 Stupid-ones and blind, for what is greater, the gift, or the altar, namely-the-one making the gift holy?

MATTHEW 25 CT

2 But five out-of them were prudent, and the five stupid. 3 They-who were stupid having-taken the torches of-themselves, took not oil with themselves;

"STUPID" IS A FAR BETTER TRANSLATION OF "moros" THAN IS THE WORD "FOOL". IF YOU COMPARE VARIOUS TRANSLATIONS YOU CANNOT HELP BUT NOTICE THAT THEY COPY EACH OTHER. IT SEEMS TO ME THAT THIS IS AN INDICATION THAT TRANSLATORS HAVE BEEN MISLED BY THE ADVERSARY. THE KING JAMES IS CONSISTENT IN ITS USE OF "FOOL" AND "FOOLISH" UNTIL EPHESIANS 5:17, ABOVE. THERE ARE ONLY 4 USES OF THE VERB "moraino". TWO OF THESE USES HAVE BEEN VIOLENTLY ALTERED WITHOUT ANY REAL JUSTIFICATION. IF CONSISTENCY IS MAINTAINED, DOES THE VERSE MAKE SENSE?

μωραίνω, mōraino.

- Mat. 5:13. but if the salt have lost his savour,
- Lu. 14:34. but if the salt have lost his savour,
- Ro. 1:22. to be wise, they became fools,
- 1Co. 1:20. hath not God made foolish the wisdom

MATTHEW 5 CT

13 YOU yourselves-are the salt of-the land: but if the salt might-be-made-stupid, with what will-it-be-salted? It-is still being-strong with-reference-to nothing, unless to-be-cast without, and to-be-being-trodden-down by the MEN.

FIRST: THE JEWS TO WHOM JESUS WAS SPEAKING WERE THEMSELVES THE SALT OF GOD'S LAND, ISRAEL. SECOND: JESUS HIMSELF REFERRED TO SOME OF HIS HEARERS AS "STUPID" AND "BLIND". THIRD: ISRAEL WAS NOT YET ABLE TO CARRY OUT GOD'S PLANS. FOURTH: ISRAEL WAS "TO-BE-BEING-TRODDEN-DOWN" BY THE ANTISEMITISM OF THE GENTILES. THIS IS ANOTHER PROPHECY AS ON PAGES 21 AND 22.

BEFORE PROCEEDING FURTHER WITH THESE PROPHECIES LET ME GIVE ANOTHER EXAMPLE TO SHOW THAT TRANSLATORS ARE UNDER THE INFLUENCE OF THE ADVERSARY.

MATTHEW 25:1

Phillips Modern English

King James Version

25 Then shall the kingdom of heaven be likened unto ten virgins, which took their lamps, and went forth to meet the bridegroom. <sup>2</sup>And five of them were wise, and five were foolish. <sup>3</sup>They that were foolish took their lamps, and took no oil with them: <sup>4</sup>But the wise took oil in their vessels with their lamps. <sup>5</sup>While the bridegroom tarried, they all slumbered and slept. <sup>6</sup>And at midnight there was a cry made, Behold, the bridegroom cometh; go ye out to meet him. <sup>7</sup>Then all those virgins arose, and trimmed their lamps. <sup>8</sup>And the foolish said unto the wise, Give us of your oil; for our lamps are gone out.

Living Bible

\*25 "The kingdom of Heaven can be illustrated by the story of ten bridesmaids" who took their lamps and went to meet the bridegroom. <sup>2</sup>, <sup>3</sup>, <sup>4</sup>But only five of them were wise enough to fill their lamps with oil, while the other five were foolish and forgot. <sup>5</sup>, <sup>6</sup>"So, when the bridegroom was delayed, they lay down to rest until midnight, when they were roused by the shout, 'The bridegroom is coming! Come out and welcome him!'" <sup>7</sup>, <sup>8</sup>"All the girls jumped up and trimmed their lamps. Then the five who hadn't any oil begged the others to share with them, for their lamps were going out.

Today's English Version

\*25 "On that day the Kingdom of heaven will be like ten girls who took their oil lamps, and went out to meet the bridegroom. <sup>2</sup>Five of them were foolish, and the other five were wise. <sup>3</sup>The foolish ones took their lamps but did not take any extra oil with them, <sup>4</sup>while the wise ones took containers full of oil with their lamps. <sup>5</sup>The bridegroom was late in coming, so the girls began to nod and fall asleep. <sup>6</sup>"It was already midnight when the cry rang out, 'Here is the bridegroom! Come and meet him!'" <sup>7</sup>The ten girls woke up and trimmed their lamps. <sup>8</sup>Then the foolish ones said to the wise ones, 'Let us have some of your oil, because our lamps are going out.'

New International Version

25 "At that time the kingdom of heaven will be like ten virgins who took their lamps and went out to meet the bridegroom. <sup>2</sup>Five of them were foolish and five were wise. <sup>3</sup>The foolish ones took their lamps but did not take any oil with them. <sup>4</sup>The wise, however, took oil in jars along with their lamps. <sup>5</sup>The bridegroom was late, and they all became drowsy and fell asleep. <sup>6</sup>"At midnight the cry rang out: 'Here's the bridegroom! Come out to meet him!'" <sup>7</sup>Then all the virgins woke up and trimmed their lamps. <sup>8</sup>The foolish ones said to the wise, 'Give us some of your oil; our lamps are going out.'

\* "In those days the kingdom of Heaven will be like ten bridesmaids who took their lamps and went out to meet the bridegroom. Five of them were foolish and five were sensible. The foolish ones took their lamps but did not take any oil with them. But the sensible ones brought their lamps and oil in their flasks as well. Then, as the bridegroom was a very long time, they all grew drowsy and fell asleep. But in the middle of the night there came a shout, 'Wake up, here comes the bridegroom! Out you go to meet him!' Then up got all the bridesmaids and attended to their lamps. The foolish ones said to the sensible ones, 'Please give us some of your oil—our lamps are going out!'"

Revised Standard Version

\*25 "Then the kingdom of heaven shall be compared to ten maidens who took their lamps and went to meet the bridegroom. <sup>2</sup>Five of them were foolish, and five were wise. <sup>3</sup>For when the foolish took their lamps, they took no oil with them; <sup>4</sup>but the wise took flasks of oil with their lamps. <sup>5</sup>As the bridegroom was delayed, they all slumbered and slept. <sup>6</sup>But at midnight there was a cry, 'Behold, the bridegroom! Come out to meet him.' <sup>7</sup>Then all those maidens rose and trimmed their lamps. <sup>8</sup>And the foolish said to the wise, 'Give us some of your oil, for our lamps are going out.'

Jerusalem Bible

\*25 "Then the kingdom of heaven will be like this: Ten bridesmaids took their lamps and went to meet the bridegroom. <sup>2</sup>Five of them were foolish and five were sensible: <sup>3</sup>the foolish ones did take their lamps, but they brought no oil, <sup>4</sup>whereas the sensible ones took flasks of oil as well as their lamps. <sup>5</sup>The bridegroom was late, and they all grew drowsy and fell asleep. <sup>6</sup>But at midnight there was a cry, 'The bridegroom is here! Go out and meet him.' <sup>7</sup>At this, all those bridesmaids woke up and trimmed their lamps, <sup>8</sup>and the foolish ones said to the sensible ones, 'Give us some of your oil: our lamps are going out.'

New English Bible

\*25 "When that day comes, the kingdom of Heaven will be like this. There were ten girls, who took their lamps and went out to meet the bridegroom. Five of them were foolish, and five prudent; when the foolish ones took their lamps, they took no oil with them, but the others took flasks of oil with their lamps. As the bridegroom was late in coming they all dozed off to sleep. But at midnight a cry was heard: 'Here is the bridegroom! Come out to meet him.'" With that the girls all got up and trimmed their lamps. The foolish said to the prudent, "Our lamps are going out;



TORCHES

\* SIX OF OUR 8 SAMPLES OF TRANSLATION DECIDED, WITHOUT AUTHORITY, THAT "VIRGINS" MUST BE GIRLS. REV.14:4.

I HAVE UNDERLINED A FEW WORDS THAT ALTER THE MEANING OF THE GREEK TEXT. WHICH OF THESE 8 WOULD YOU CALL "THE WORD OF GOD"? REMEMBER THE ADVERSARY HATES ISRAEL. THEREFORE HE TENDS TO INFLUENCE THE TRANSLATORS TO TRANSLATE AS THOUGH ISRAEL DID NOT EXIST. THE GOSPELS ARE CONCERNED WITH ISRAEL, BECAUSE THEY ARE NOT WELL UNDERSTOOD BY GENTILES THERE IS A TENDENCY TO TRANSLATE AS THOUGH PARABLES ARE "STORIES". VERY IMPORTANT THEOLOGY IS CONCEALED. LET US EXAMINE ONE SUCH CASE WHERE THE TRANSLATION OF ONE WORD CONCEALS THE TRUTH.

### King James Version

24 Therefore whosoever heareth these sayings of mine, and doeth them, I will liken him unto a wise man, which built his house upon a rock: 25 And the rain descended, and the floods came, and the winds blew, and beat upon that house; and it fell not: for it was founded upon a rock. 26 And every one that heareth these sayings of mine, and doeth them not, shall be likened unto a foolish man, which built his house upon the sand: 27 And the rain descended, and the floods came, and the winds blew, and beat upon that house; and it fell: and great was the fall of it. 28 And it came to pass, when Jesus had ended these sayings, the people were astonished at his doctrine: 29 For he taught them as *one* having authority, and not as the scribes.

### Living Bible

24 "All who listen to my instructions and follow them are wise, like a man who builds his house on solid rock. 25 Though the rain comes in torrents, and the floods rise and the storm winds beat against his house, it won't collapse, for it is built on rock."

26 "But those who hear my instructions and ignore them are foolish, like a man who builds his house on sand. 27 For when the rains and floods come, and storm winds beat against his house, it will fall with a mighty crash." 28 The crowds were amazed at Jesus' sermons. 29 for he taught as one who had great authority, and not as their Jewish leaders."

### ★ Today's English Version

24 "So then, everyone who hears these words of mine and obeys them will be like a wise man who built his house on the rock. 25 The rain poured down, the rivers flooded over, and the winds blew hard against that house. But it did not fall, because it had been built on the rock."

26 "But everyone who hears these words of mine and does not obey them will be like a foolish man who built his house on the sand. 27 The rain poured down, the rivers flooded over, the winds blew hard against that house, and it fell. What a terrible fall that was!"

### New International Version

24 "Therefore, everyone who hears these words of mine and puts them into practice is like a wise man who built his house on the rock. 25 The rain came down, the streams rose, and the winds blew and beat against that house; yet it did not fall, because it had its foundation on the rock. 26 But everyone who hears these words of mine and does not put them into practice is like a foolish man who built his house on sand. 27 The rain came down, the streams rose, and the winds blew and beat against that house, and it fell with a great crash."

28 When Jesus had finished saying these things, the crowds were amazed at his teaching, 29 because he taught as one who had authority, and not as their teachers of the law.

### MATTHEW 7:24-29



### Phillips Modern English

★ "Everyone then who hears these words of mine and puts them into practice is like a sensible man who builds his house on rock. Down came the rain and up came the floods, while the winds blew and roared upon that house—and it did not fall because its foundations were on rock."

★ "And everyone who hears these words of mine and does not follow them can be compared with a foolish man who built his house on sand. Down came the rain and up came the floods, while the winds blew and battered that house till it collapsed, and fell with a great crash."

When Jesus had finished these words the crowd were astonished at the power behind his teaching. For his words had the ring of authority, quite unlike those of their scribes.

### Revised Standard Version

24 "Every one then who hears these words of mine and does them will be like a wise man who built his house upon the rock; 25 and the rain fell, and the floods came, and the winds blew and beat upon that house, but it did not fall, because it had been founded on the rock. 26 And every one who hears these words of mine and does not do them will be like a foolish man who built his house upon the sand; 27 and the rain fell, and the floods came, and the winds blew and beat against that house, and it fell; and great was the fall of it."

28 And when Jesus finished these sayings, the crowds were astonished at his teaching, 29 for he taught them as one who had authority, and not as their scribes.

### Jerusalem Bible

24 "Therefore, everyone who listens to these words of mine and acts on them will be like a sensible man who built his house on rock. 25 Rain came down, floods rose, gales blew and hurled themselves against that house, and it did not fall: it was founded on rock. 26 But everyone who listens to these words of mine and does not act on them will be like a stupid man who built his house on sand. 27 Rain came down, floods rose, gales blew and struck that house, and it fell; and what a fall it had!"

### New English Bible

★ "What then of the man who hears these words of mine and acts upon them? He is like a man who had the sense to build his house on rock. The rain came down, the floods rose, the wind blew, and beat upon that house; but it did not fall, because its foundations were on rock. But what of the man who hears these words of mine and does not act upon them? He is like a man who was foolish enough to build his house on sand. The rain came down, the floods rose, the wind blew, and beat upon that house; down it fell with a great crash."

When Jesus had finished this discourse the people were astounded at his teaching; unlike their own teachers he taught with a note of authority.

ON PAGE 25 I HAVE GIVEN THE 12TH EXAMPLE COMPARING 8 "BIBLE" TRANSLATIONS. THIS PASSAGE IS A "PARABLE"; MEANING "TO CAST BESIDE". IN THIS CASE WE MUST ASK, TO CAST BESIDE WHAT? HERE ARE SOME IMPORTANT FACTS. (SEE PAGE 22.)

1. In Greek, the article acts as a pointer, to what?
2. In Matthew 7:24 "the" points to "the rock". What rock?
3. Five of these 8 translators omit the article. These end up with stories, not a parable. These are not the "word of God". ★
4. Those who read these 5 translations will usually apply the story to "Christians". This parable was spoken to Jews.
5. The Greek word "potamos" means "river". Read Mark 1:5, the river of Jordan. This Greek word occurs 16 times. King James uses: flood 4x, river 9x, stream 2x and water once.
6. Of these 8 translations; 6 use "floods"; 1 uses "streams", and 1, Today's English Version correctly uses "rivers". ★
7. The word "rivers" will be the key word to establish this passage as a parable. (Rev. 12:15,16).

#### EXODUS 17 ASV

3 And the people thirsted there for water; and the people murmured against Moses, and said, "Wherefore hast thou brought us up out of Egypt, to kill us and our children and our cattle with thirst?" 4 And Moses cried unto Jehovah, saying "What shall I do unto this people? they are almost ready to stone me." 5 And Jehovah said unto Moses, "Pass on before the people, and take with thee of the elders of Israel; and thy rod, wherewith thou smotest the river, take in thy hand, and go." 6 Behold, I will stand before thee there upon the rock in Horeb; and thou shalt smite the rock, and there shall come water out of it, that the people may drink. And Moses did so in the sight of the elders of Israel.

#### DEUTERONOMY 32 ASV

18 Of the Rock that beget thee thou art unmindful,  
"And hast forgotten God that gave thee birth."

#### 2 SAMUEL 22 ASV

32 "For who is God, save Jehovah?  
"And who is a rock, save our God?"

#### 2 SAMUEL 23 ASV

3 The God of Israel said,  
"The Rock of Israel spake to me:"

#### PSALMS 78 ASV

20 Behold, he smote the rock, so that waters gushed out, And streams overflowed;  
Can he give bread also?  
Will he provide "flesh for his people?"



#### PSALMS 114 ASV

8 Who turned the rock into a pool of water,  
The "hint into a fountain of waters."

#### PSALMS 105 ASV

41 He opened the rock, and waters gushed out;  
They ran in the dry places like a river."

#### ISAIAH 48 ASV

20 "Go ye forth from Babylon, flee ye from the Chaldeans; with a voice of "singing declare ye, tell this, " utter it even to the end of the earth: say ye, " Jehovah hath redeemed his servant Jacob,  
21 And they "thirsted not when he led them through the deserts; he "caused the waters to flow out of the rock for them; he clave the rock also, and "the waters gushed out. 22 "There is no peace, saith Jehovah, to the wicked."

#### NUMBERS 20 ASV

7 And Jehovah spake unto Moses, saying, 8 Take the rod, and assemble the congregation, thou, and Aaron thy brother, and speak ye unto the rock before their eyes, that it give forth its water; and thou shalt bring forth to them water out of the rock; so thou shalt give the congregation and their cattle drink. 9 And Moses took the rod from before Jehovah, as he commanded him.

10 And Moses and Aaron gathered the assembly together before the rock, and he said unto them, Hear now, ye rebels; shall we bring you forth water out of this rock? 11 And Moses lifted up his hand, and smote the rock with his rod twice; and "water came forth abundantly, and the congregation drank, and their cattle. 12 And Jehovah said unto Moses and Aaron, "Because ye believed not in me, to sanctify me in the eyes of the children of Israel, therefore ye shall not bring this assembly into the land which I have given them."

#### NEHEMIAH 9 ASV

15 and "gavest them bread from heaven for their hunger, and "broughtest forth water for them out of the rock for their thirst, and "commandedst them that they should go in to possess the land which thou hadst "sworn to give them."

#### PSALMS 78 ASV

15 He clave rocks in the wilderness,  
And gave them drink abundantly as out of the depths.  
16 He "brought streams also out of the rock,  
And caused waters to run down like rivers."



"THE GOD OF ISRAEL SAID, THE ROCK OF ISRAEL SPAKE TO ME".  
 (2 SAM.23:3,PAGE 26) JEHOVAH STOOD UPON THE ROCK IN HOREB. (P.26)  
 THERE SHOULD BE NO DOUBT THAT "THE ROCK" IN THE PARABLE ON PAGE 25  
 IS JEHOVAH. THIS JEHOVAH, THE SON, IS THE MESSIAH OF ISRAEL. "AND  
 THEY ALL DRANK THE SAME SPIRITUAL DRINK; FOR THEY-WERE-DRINKING  
 OUT-OF A SPIRITUAL ROCK FOLLOWING, BUT THE ROCK WAS THE MESSIAH".  
 (1 CORINTHIANS 10:4 CT)

"RIVERS" IN THE PARABLE INDICATE A DESTRUCTIVE FORCE AGAINST  
 GOD'S PEOPLE. WHERE DOES THIS DESTRUCTIVE FORCE ORIGINATE? THE  
 WORD "RIVER" IS THE CONNECTING LINK FOR THE PARABLE. LET US GO  
 BACK TO REVELATION 12:15.

REVELATION 12 CT

15 And the serpent cast out-of his mouth behind the  
 woman water as a river, in-order-that he-might-make her  
carried-off-by-the-river.

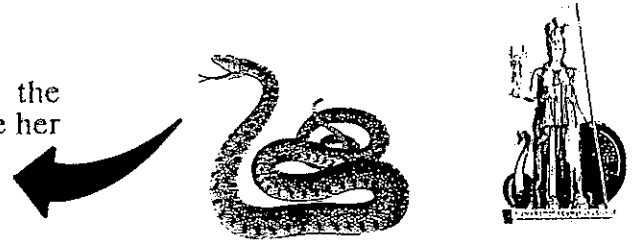

DANIEL 7 ASV

8 I considered  
 the horns, and, behold, there  
 came up among them "another  
 horn, a little one, before which  
 three of the first horns were  
 plucked up by the roots: and,  
 behold, in this horn were eyes  
 like the eyes of a man, and a  
 mouth speaking "great things.

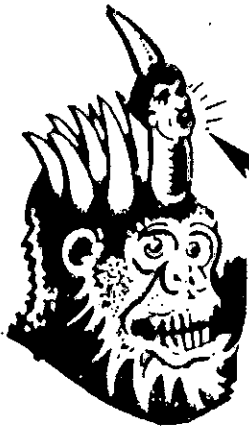

REVELATION 12 CT

16 And the earth helped the woman, and the earth opened  
 its mouth and swallowed the river which the dragon cast  
 out-of his mouth.

JOHN 4 CT

14 But who might-drink out-of the water which I myself-  
 shall-give to-him he-might by-no-means thirst with-refer-  
 ence-to the age, BUT the water which I-shall-give to-him  
 will-become in him a spring of-water springing-up with-  
 reference-to life eternal.

ISAIAH 8 ASV

5 And Jehovah spake unto me  
 yet again, saying, 6 Forasmuch  
 as this people have refused the  
 waters of "Shiloah that go softly,  
 ' and rejoice ' in ' Rezin and Rem-  
 aliah's son; 7 now therefore, be-  
 hold, the Lord bringeth up upon  
 them the "waters of "the River,  
strong and many, even the "king  
 of Assyria and all his glory: and  
 it shall ' come up over all its  
 channels, and go over all its  
 banks; 8 and ' it shall sweep  
 onward into Judah; it shall over-  
 flow and pass through; it shall  
 "reach even to the neck; and  
 the stretching out of its wings  
shall fill the breadth of thy land,  
 " O Immanuel.

The parable of Matthew 7:24-29  
 in the CT is shown on page 28. This  
 parable connects with Revelation 12.  
 The details are important in both  
 passages. Isaiah 8 shows the "waters  
 of the river" as a destructive force,  
 in that case a military force.

IT IS VERY IMPORTANT TO HAVE THE ENGLISH TRANSLATION AS CLOSE  
 TO THE GREEK TEXT AS POSSIBLE. THIS PARABLE WILL GIVE YOU A GOOD  
 EXAMPLE TO PROVE THIS FACT. NOTE THE DIFFERENCES BETWEEN VERSE 15  
 AND VERSE 16. THE SERPENT CASTS OUT WATER "AS A RIVER" WHILE THE  
 DRAGON CASTS OUT "THE RIVER".

The serpent hides himself in the "church", and does as he did  
 in the Garden of Eden. He challenges the Word of God, "Yea, hath  
 God said?" It is the serpent that teaches that God is through with  
 the Jews. The serpent teaches that the "church" is the true  
 Israel. It is the serpent, within the "church", that coined the  
 phrase "Christ killers". Antisemitism, "as a river" caused the  
 death of millions of God's chosen people. (See pages 5 and 18).

The dragon casts out "the river" as a destructive force. It is as the dragon that Zeus or Satan operates among the world powers. We have already seen his authority over the old Roman Empire. His primary authority today rests in the Roman Ecumenical Assembly, as we shall see later. The serpent was the one active in the false religions, as you can see from the statue of Athene.

MATTHEW 7 CT

24 Every-one therefore, one-who is-hearing these my words, and is-doing them, I-shall-likened him to-a-prudent man, one-who built-up his house upon the rock;

25 And the rain descended, and the rivers came, and the winds blew, and they-fell-against that house, and it-fell not; for it-had-been-founded upon the rock,

26 And every-one, the-one hearing these my words and doing them not, he-will-be-likened to-a-stupid man, one-who built-up his house upon the sand:

27 And the rain descended, and the rivers came, and the winds blew, and they-pounded that house, and it-fell, and the falling-of-it was great.

28 And it-came-to-pass when the Jesus finished these-words completely the crowds were-being-surprised upon his doctrine.

29 For he-was teaching them as having authority, and not as the scribes.

This parable is strictly to Jews, not to Gentiles. The Jews knew Jehovah as "the rock". Jews face ANTISEMITISM throughout the world, not Gentiles. Jews are hated because they are Jews, chosen by God as his "own possession". (page 18).

THE CONTINUAL EXISTENCE OF THE JEWS AND THE FACT THAT ALL SCRIPTURE WAS GIVEN TO JEWS BY GOD IS BY FAR THE MOST CONCLUSIVE PROOF THAT THE BIBLE IS THE WORD OF GOD.

THE EARLY CHRISTIAN CHURCH IN THE ROMAN EMPIRE, ENCY. BRIT. p.3

With nationalistic Judaism squelched in the East, Rome did not proceed vigorously against Jews in other areas, and probably did not clearly distinguish Christians from Jews until about the end of the first century. Complicating the confusion during this period was the tacit exemption of Jews from emperor worship and the Christians' claim that they were the true Jews, the true continuation and heirs of the ancient prophecies and promises.

A BRIEF SUMMARY INDEX TO THIS POINT:

1. THE WORD OF GOD IS IN GREEK AND HEBREW. (COVER).
2. REVELATION 12 SHOWS THE CONFLICT BETWEEN ISRAEL AND THE ADVERSARY. (PAGE 1).
3. THE ADVERSARY IS LEADING ASTRAY THE TOTAL INHABITED EARTH. (PAGE 2).
4. THE ADVERSARY CAN AND DOES INFLUENCE HOW "TRANSLATORS" VIEW THE WORD OF GOD. (PAGES 3&4).
5. THE ADVERSARY'S AUTHORITY, (PAGES 5&6) AND HOW THIS AUTHORITY IS OPERATING THROUGH THE ADVERSARY'S ANGELS. THESE ANGELS WERE CALLED "DEMONS" OR SOMETIMES "GENIUSES". (PAGES 7&8).
6. THE SLANDERER RAISES MINISTERS WITHIN THE "CHURCHES" AND THEOLOGICAL SCHOOLS. (PAGES 9-11).
7. THE DRAGON, THE ADVERSARY ZEUS, SATAN IF YOU PREFER, IS ALLOWED BY GOD TO HAVE GREAT AUTHORITY. (PAGES 11-17).
8. JEHOVAH RAISED UP HIS CHOSEN PEOPLE THROUGH ABRAHAM. GOD IS PERFECTING HIS NATION ISRAEL. (PAGES 18&19).
9. JEHOVAH'S PROMISES TO HIS PEOPLE, ESPECIALLY HIS LAND GRANT, ARE BEING MADE CLEAR. (PAGES 20,20A). EVERY DAY.
10. JESUS' WARNINGS OF THE ANTISEMITISM THAT ISRAEL WILL SUFFER AT THE HAND OF THE GENTILES. (PAGES 21-28).

REVELATION 12 CT ISRAEL

1 And a great sign was-seen in the heaven, a woman having-been-and-still-cast-around with the sun, and the moon underneath her feet and on her head a crown of-stars twelve,

JESUS

5 And she-brought-forth a son, a male, who is-about to-be-shepherding all the Gentiles with an iron rod; and her child was-seized to the God and to his throne.

6 And the woman fled into the wilderness, where-in-which she-is-having there a place having-been-and-still-prepared from the God, in-order-that there they-might-be-nourishing her a thousand two-hundred sixty days.

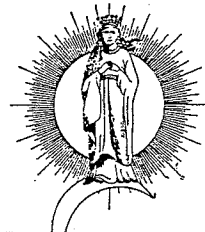

FIRST FLIGHT

2 And having in her womb, and suffering-birth-pains she-is-crying and being-tormented to-bring-forth,

ZION

INHABITED-EARTH AUTHORITY

3 And another sign was-seen in the heaven, and behold, a great dragon red-as-fire, having seven heads and ten horns and on his heads seven diadems,

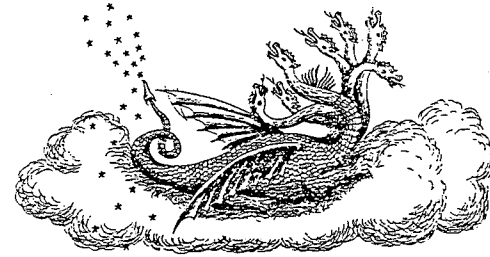

4 And his tail is-dragging the third of-the stars-of-the heaven, and he-cast them into the earth. And the dragon has-stood-and-still-stands in-sight-of-the woman namely-the future one to-bring-forth, in-order-that at-the-time-that she-might-bring-forth he-might-devour her child.

STATE OF ISRAEL

SEE REVELATION 7:14

12 Because-of this YOU-be-being-merry-for-yourselfes, heavens and the ones tabernacling in them; woe to-the ones residing on the earth and the sea, because the slanderer descended to YOU having great anger, knowing-absolutely that he-is-having a little-bit season.

13 And when the dragon saw that he-was-cast into the earth, he-pursued the woman, one-who brought-forth the male.

14 And the two wings-of-the eagle namely-the great one were-given-to-the woman, in-order-that she-might-be-fly-ing into the wilderness into her place, where-in-which she-is-being-nourished there a season and seasons and half of-a-season from face-of-the serpent.

SECOND FLIGHT

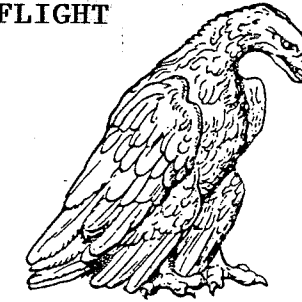

"AS A RIVER" VERSUS "THE RIVER"

15 And the serpent cast out-of his mouth behind the woman water as a river, in-order-that he-might-make her carried-off-by-the-river.

16 And the earth helped the woman, and the earth opened its mouth and swallowed the river which the dragon cast out-of his mouth.

17 And the dragon was-made-wroth over the woman, and he-went-away to-make war with the others-of-her seed, the ones keeping the commandments-of-the God and having the witness of Jesus.

HEBREW-CHRISTIANS

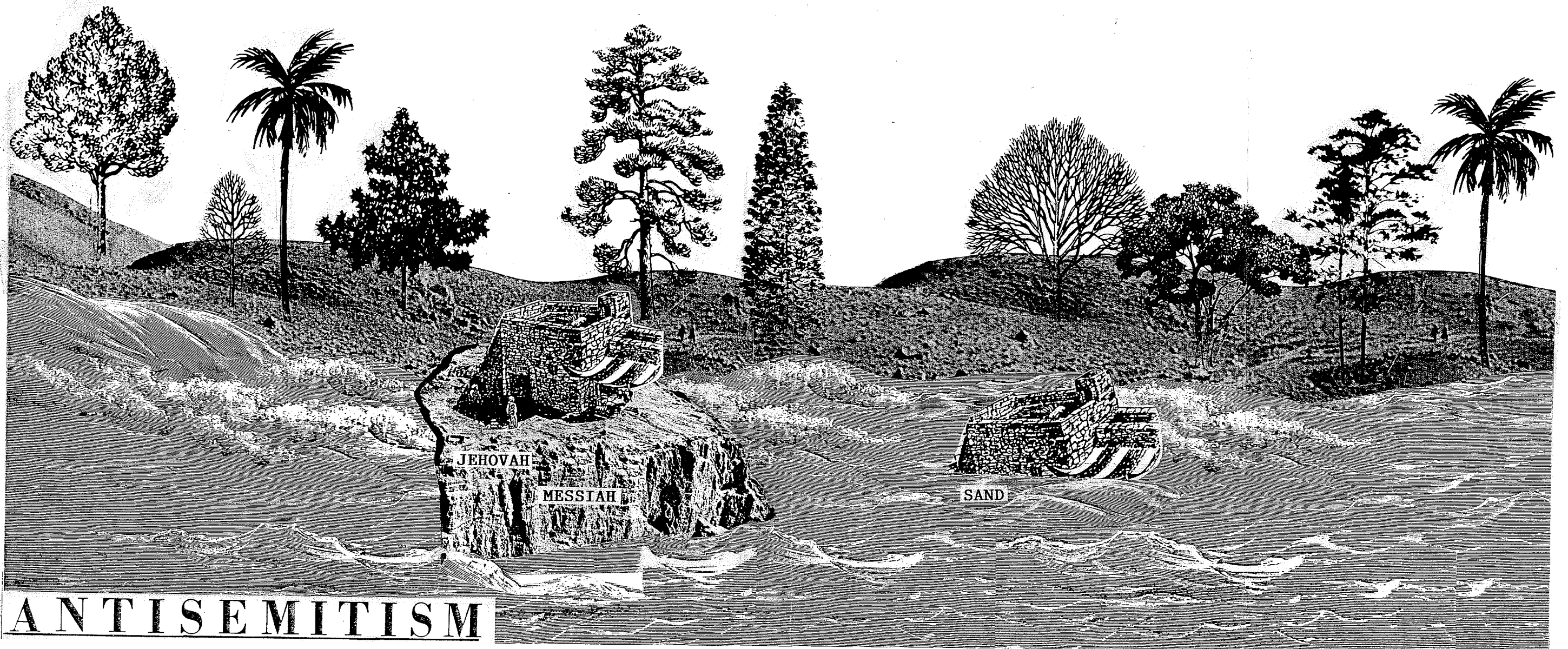

WE HAVE NOW GATHERED SOME FACTS WHICH SHOULD HELP US TO UNDERSTAND THE EVENTS OF REVELATION 12 MUCH BETTER. IN REV.12:1 IT SHOULD BE VERY CLEAR THAT THE FIRST SIGN, THE WOMAN, IS THE NATION OF ISRAEL. CONSIDER VERSE 2 VERY CAREFULLY. THIS WOMAN, ISRAEL, IS SAID TO BE "HAVING IN HER WOMB",\*A LONG WAY FROM DELIVERY. SHE IS NEVERTHELESS ALREADY SAID TO BE "SUFFERING-BIRTH-PAINS". THIS WAS THE NATION ISRAEL CONSTANTLY SUFFERING UNDER ANTISEMITISM, LONGING TO BE RESTORED TO HER LAND.

NOW SKIP TO VERSE 5. HERE IS ANOTHER BIRTH. THIS BIRTH IS IS THE BIRTH OF JESUS, WHICH WE HAVE ALREADY SHOWN ON PAGE 17. NOW RETURN TO VERSE 4, WHERE WE LEARN THAT THE DRAGON KEEPS THE WOMAN IN SIGHT. THIS VERSE DESCRIBES THE WOMAN FURTHER. SHE IS THE "FUTURE" (WOMAN) TO BRING FORTH. THE DRAGON WAITS, IN ORDER TO "DEVOUR" HER CHILD. THIS CHILD IS NOT JESUS, BUT THE NATION OF ISRAEL.

"BEFORE SHE TRAVAILED, SHE BROUGHT FORTH; BEFORE HER PAIN CAME, SHE WAS DELIVERED OF A MANCHILD". ISAIAH 66:7-9. ASV

NOW GO TO VERSE 6 FOR A MOMENT. THE WOMAN (ISRAEL) FLED INTO THE WILDERNESS FOR A 1260 DAY PERIOD. THERE IS NO BIBLICAL REASON THAT I KNOW TO EQUATE THIS FLIGHT WITH VERSE 14. IN VERSE 14 THE WOMAN "FLIES" INTO THE WILDERNESS FOR "A SEASON AND SEASONS AND HALF OF-A-SEASON FROM THE FACE OF THE SERPENT". I BELIEVE THAT THESE ARE TWO VERY DIFFERENT OCCASIONS.

\*TEACHING DICTIONARY PAGE 57

#### LUKE 21 CT

20 But at-the-time-that YOU-might-see the Jerusalem being-encircled by camps, then YOU-come-to-know that her desolation has-drawn-near-and-is-still-near.

21 Then let the-ones in the Judea be-fleeing into the mountains, and let the-ones in midst of-her (*Jerusalem*) be-emigrating, and let not the-ones in the cultivated-fields be-going-in into her. (*Jerusalem*)

22 Because these are days of-an-avenging, all the-things having-been-and-still-written to-be-fulfilled.

23 But woe to-the-ones having-in womb and to-the-ones nursing in those days, for there-will-be great necessity over the land and wrath for-this people.

24 And they-will-fall by-mouth of-dagger, and they-will-be-led-captive into all the Gentiles; and Jerusalem will-be being-trodden by nations until seasons of-nations might-be-fulfilled.

THE WARS OF THE JEWS, JOSEPHUS, BOOK 2, XX.  
THE DEFEAT OF CESTIUS GALLUS, FIRST FLIGHT.  
APOLOGETICS 25, PAGE 3, 1260 DAYS.

This defeat happened on the eighth day of the month Dius [Marhesvan], in the twelfth year of the reign of Nero.

§ 1. AFTER this calamity had befallen Cestius, many of the most eminent of the Jews swam away from the city, as from a ship when it was going to sink:

The one leading-astray the total inhabited-earth,  
ὁ σατανᾶς, the adversary, the dragon, the great,  
ὁ διάβολος, the slanderer, the serpent, the ancient.

JESUS WARNS OF FIRST FLIGHT OF 1260 DAYS. SEE JOSEPHUS BELOW.

JESUS PROPHESED THE LONG DIASPORA OF THE JEWS ALSO. THIS TIME PERIOD WAS COMPLETED JUNE 7, 1967.

THE ADVERSARY HAS NOT GIVEN UP HIS EFFORT TO DEVOUR THE CHILD. CONSIDER THE ACTIVITY OF THE SERPENT AS WELL AS THE DRAGON, HAVING MOVED INTO THE 7TH WORLD POWER,

SEE PAGES 14 & 15

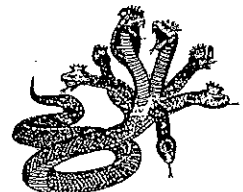



THE DRAGON IN REV. 12:3 IS IDENTIFIED FOR US IN VERSE 9. THE DRAGON WEARS 7 DIADEMS, THE "CROWN" OF A WORLD RULER; BUT NOT A VICTOR'S CROWN. THE DRAGON HAS, FOR SOME REASON, BEEN GIVEN THE AUTHORITY TO RULE OVER 7 WORLD POWERS: EGYPT, ASSYRIA, BABYLON, MEDO-PERSIA, GREECE, ROME AND THE ROMAN ECUMENICAL ASSEMBLY. AFTER JESUS WAS CRUCIFIED, BURIED, RAISED FROM THE DEAD AND SEIZED UP TO GOD; IT SEEMS TO ME THAT THE WAR TOOK PLACE IN HEAVEN. THE RESULT IS IN REV. 12:7,8,9. VICTORY WAS NOW ASSURED TO GOD AND ISRAEL. THE WOMAN IN VERSE 1 ALREADY WORE A VICTOR'S CROWN (STEPHANOS). JESUS ALSO NOW WEARS THE VICTOR'S CROWN, REV. 14:14. THE CRY OF VICTORY IS HEARD IN HEAVEN.

#### REVELATION 12 CT

10 And I-heard a <sup>★</sup>great voice in the heaven saying: Just now came-to-pass the salvation and the power and the kingdom of-our God and the authority of-his Messiah, because the accuser of-our brothers was-cast-down, the one accusing them in-sight-of-our God of-day and of-night.

11 And they themselves-had-victory-over him because-of the blood of-the Lamb and because-of the word of-their witness, and they-cherished not their soul unto death.

12 Because-of this YOU-be-being-merry-for-yourselves, heavens and the *ones* tabernacling in them; woe to the *ones* residing on the earth and the sea, because the slanderer descended to YOU having great anger, knowing-absolutely that he-is-having a little-bit season.

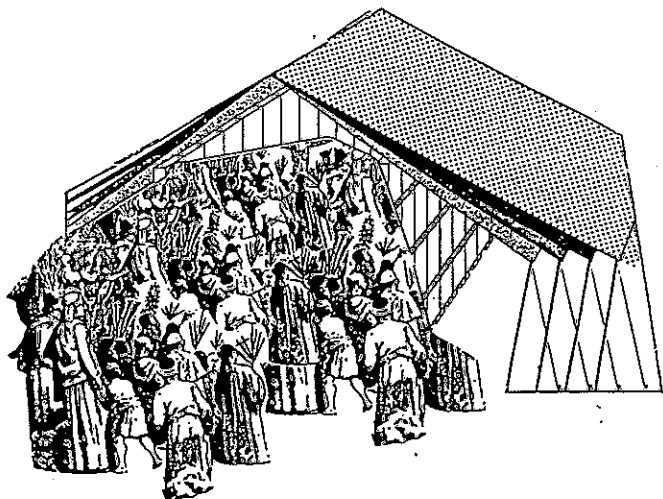

#### REVELATION 7 CT

9 After these things I-saw, and behold much crowd, and which not-one was-being able to-number it, out-of every nation and of-tribes and of-peoples and of-languages, having-stood-and-still-standing in-sight of-the throne and in-sight of-the Lamb, having-been-and-still-cast-around with white stolees, and palms in their hands; <sup>★</sup>

10 And they-are-crying with-a-great voice saying: The salvation to our God namely-the one sitting on the throne and to-the Lamb.

14 And I-have-said-and-still-say to him: My lord, you yourself know-absolutely. And he said to-me: These are the ones coming out-of the tribulation, namely-the great one, and they-washed their stolees and they-whitened them in the blood of-the Lamb,

15 Because-of this they-are in-sight of-the throne of-the God, and they-are-serving him of-day and of-night in his sanctuary, and the one sitting on the throne will-tabernacle on them.

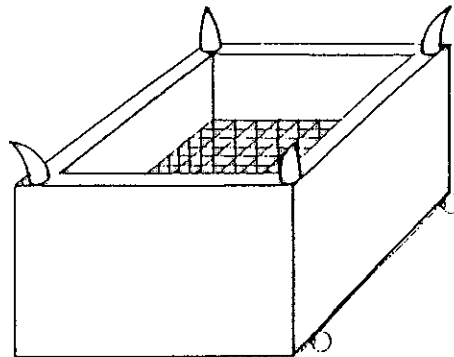

Judge and avenge our blood on the ones residing on the earth



Given white stolees

#### REVELATION 6 CT

9 And when he-opened the fifth seal, I-saw underneath of-the altar the souls of-the *ones* having-been-and-still-slain because-of the word of-the God and because-of the witness which they-were-having. <sup>★</sup>

10 And they-cried with-a-great voice saying: Till at-what-time, the Despot namely-the holy and authentic, are-you not judging and avenging our blood out-of the ones residing on the earth?

11 And a white stolee was-given to-them each one, and it was said to-them in-order-that they-themselves-might-rest-again yet a little time, till also their fellow-slaves and their brothers namely-the future ones to-be-being-killed also as they, might fulfill their lives.

#### PSALMS 44 ASV

22 Yea, <sup>2</sup>for thy sake are we killed <sup>2</sup>all the day long; We are accounted as <sup>2</sup>sheep for the slaughter.

23 <sup>2</sup>Awake, why <sup>2</sup>sleepest thou, O Lord? Arise, 'cast us not off for ever.

THE VERB "TO TABERNACLE" OCCURS 3 TIMES IN REVELATION WITH REFERENCE TO "TABERNACLING" IN THE HEAVENS. TWO OF THESE REFERENCES ARE SHOWN ON PAGE 30. (REV. 12:12 AND REV. 7:15) THE LAST OF THE THREE, REV. 13:6, IS BELOW ON THIS PAGE. IT SEEMS TO ME THAT THE "GREAT TRIBULATION" HAD BEGUN EVEN BEFORE THE SLANDERER HAD BEEN CAST DOWN.

REVELATION 13 CT

6 And it-opened its mouth with-reference-to blasphemies toward the God, to-blaspheme his name and his tabernacle and the ones tabernacling in the heaven.

AT THE BEGINNING OF THE NEW TESTAMENT ASSEMBLY THE MEMBERS WERE ALL JEWS. AT PENTECOST, THE SMALL GROUP HAVING GATHERED WERE ALL JEWS. IT WAS GOD'S PURPOSE TO ADD GENTILES TO THE JEWISH BELIEVERS. (ROMANS 11)

THE DRAGON IN THE PAST HAD AUTHORITY IN THE GREEK EMPIRE, THEN IN THE ROMAN. THE MAJORITY OF JEWS LIVED WITHIN THESE EMPIRES AND WERE SUBJECT TO HIS ATTACK. (REV. 12:4) THE SERPENT BEGAN A NEW ATTACK, IN PREPARATION TO BEGINNING A NEW KIND OF EMPIRE. HE "CAST OUT-OF HIS MOUTH BEHIND THE WOMAN WATER AS A RIVER". FIRST, HOWEVER, THE DRAGON WITH HIS ROMAN AUTHORITY DESTROYED JERUSALEM AND THE TEMPLE. MANY JEWS HAD BEEN IN A "DIASPORA". THE JEWS WERE NOW IN "GALUT", THAT IS, THEY WERE SCATTERED WITHOUT A HOMELAND. THE SERPENT CONTINUED TO USE AN OLD TACTIC WHICH HAD BEEN VERY SUCCESSFUL, A SIMPLE MATTER OF A PIG.

REVELATION 12 CT

13 And when the dragon saw that he-was-cast into the earth, he-pursued the woman, one-who brought-forth the male.

14 And the two wings of-the eagle *namely-the great one* were-given-to-the woman, in-order-that she-might-be-fly-ing into the wilderness into her place, where-in-which she-is-being-nourished there a season and seasons and half of-a-season from face of-the serpent.

15 And the serpent cast out-of his mouth behind the woman water as a river, in-order-that he-might-make her carried-off-by-the-river.

THE BOOK OF JEWISH KNOWLEDGE

p.5 BY NATHAN AUSUBEL, 1964

Among all the animals forbidden to Jews, none was fenced off with more severe and uncompromising strictures than the pig. Until recent times, the eating of pork (chazzir in Hebrew; chazzer in Yiddish) was considered by the believing Jew to be equal to apostasy; even today, many Orthodox Jews consign a Jew who eats pork to the lost and the damned. The folk-Jew, outraged in his sensibilities, expected that the rascal would have to expiate for this cardinal sin in the fiery furnace of Gehinnom (Gehenna), the original Jewish model for the Christian Hell. So notorious was this revulsion of the Jew against the flesh of the pig that, when the Seleucid king, Antiochus (Epiphanes) IV, after he had overrun Judea, ordered the Jews to sacrifice pigs on their altars, including the one in the Temple in Jerusalem, the decree stirred up such horror and outrage among the conquered Jewish people that it sparked the popular revolt led by the Maccabees in 168 B.C.E.

The baffling fact is that no Jewish religious observance aroused so much ridicule and resentment among the anti-Semites through history as the taboo against eating pork. Both Philo of Alexandria and Josephus of Rome, outstanding chroniclers of their time, mention the jeering mobs who harassed Jews on the streets, forcing them publicly to eat the flesh of swine. German anti-Semites of the Middle Ages, not unlike their later Nazi counterparts, obscenely caricatured the Jew in association with the pig (one or two old churches even illustrated this subject permanently in sculpture).

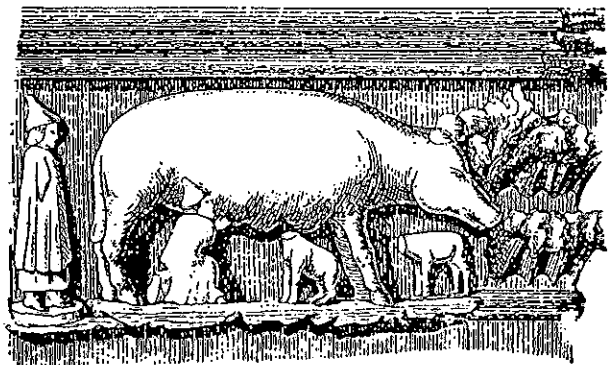

*In Germany, the Jewish religious prohibition against eating swine's flesh was treated with ridicule. Sculptured in relief in the Regensburg Cathedral is the so-called Jewish Sow (Judensau), 13th century.*

HARDLY WHAT ONE WOULD CALL  
A "CHRISTIAN CHURCH".

AS YOU CAN SEE THIS PARTICULAR ATTACK BY THE SERPENT BEGAN LONG AGO, AND STILL CONTINUES. ONCE GENTILES IN GREAT NUMBERS WERE PROFESSING TO BE BECOMING "CHRISTIANS", THEY SOON GREATLY OUT-NUMBERED THE HEBREW CHRISTIANS.

JERUSALEM FELL TO THE ROMANS IN 70 A.D. THE CITY AND THE TEMPLE WERE DESTROYED. THE LAMPSTAND FROM THE TEMPLE WAS CARRIED TO ROME. MANY THOUSANDS OF JEWS WERE KILLED AND TENS OF THOUSANDS WERE SOLD INTO SLAVERY. I BELIEVE THIS EVENT MARKED THE END OF THE EPHEBUS PERIOD OF CHURCH HISTORY IN REVELATION 1.

THE BOOK OF JEWISH KNOWLEDGE, NATHAN AUSUBEL, 1964, PAGES 126&311



The Golden Trumpets (right) of the Temple in Jerusalem. (From the engraving by Pietro Santo Bartoli (1635-1700), reproducing the triumphal procession of the Romans with the Temple spoils on the sculptured reliefs of the Arch of Titus, Rome.)

#### REVELATION 2 CT

1 To-the messenger of-the assembly in Ephesus you write: These-things-here the *one* retaining the seven stars in his right hand, the *one* walking-around in midst of-the seven lampstands, *namely-the ones* made-of-gold, is-saying:

5 You-be-having-in-memory therefore from-whence you-have-fallen-and-are-still-fallen, and you-repent and you-do the first works; but if not, I-am-coming to-you and I-shall-move your lampstand out of its place, if not you-might-repent.

8 And to-the messenger of-the assembly in Smyrna you-write: These-things-here the first and the last, who became dead and he-himself-lived is-saying:

9 I-know-absolutely your tribulation and poverty, BUT you-are rich, and the blasphemy out-of the ones saying themselves to-be Jews, and they-are not BUT synagogue of-the adversary.

Judaea Capta—"Captive Judea." Roman "victory" coin issued by Titus following the Destruction.

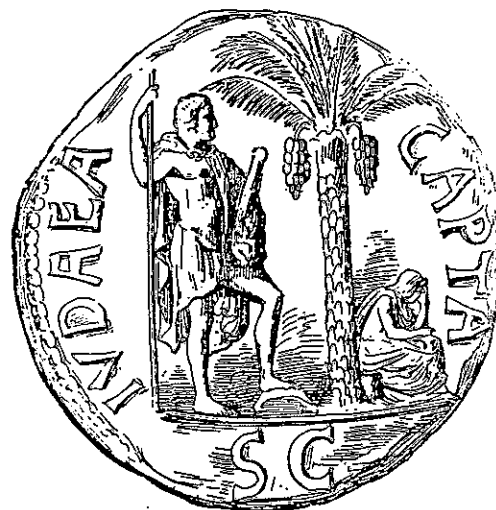

VERY EARLY IN CHURCH HISTORY THE GENTILES, WHO HAD PROFESSED CHRISTIANITY, BEGAN TO CLAIM THAT THEY WERE THE TRUE JEWS. REVIEW PAGE 28 WHERE THIS FACT IS SHOWN. SCRIPTURE BEARS THIS OUT. GOD BRANDS THEM AS MEMBERS OF THE SYNAGOGUE OF THE ADVERSARY, REV.2:9.

Ante-Nicene Fathers V1,p.200  
Justin Martyr, abt.165 A.D.

→ For the true spiritual Israel, and descendants of Judah, Jacob, Isaac, and Abraham (who in uncircumcision was approved of and blessed by God on account of his faith, and called the father of many nations), are we who have been led to God through this crucified Christ, as shall be demonstrated while we proceed.

JUSTIN MARTYR WAS A GENTILE, 110-165 A.D. HE WAS BORN IN SAMARIA. APOLOGETICS 24. DURING THIS PERIOD THERE WERE, SO THE CATHOLIC CHURCH MAINTAINS, ABOUT 11 POPES.

THE SERPENT ASPECT OF THE DRAGON WAS VERY ACTIVE SLANTING THE MEANING OF GOD'S WORD. PERHAPS WE SHOULD MAKE ALLOWANCES FOR THE EARLY CHRISTIANS. JOHN HAD NOT WRITTEN REVELATION UNTIL AT LEAST 70 A.D. IT WOULD BE A LONG TIME BEFORE PRINTING WAS INVENTED. VERY FEW PERSONS HAD ANY COPIES OF THE NEW TESTAMENT. THE NUMBER WHO COULD READ OR WRITE WAS VERY LIMITED. THE SERPENT COULD INFLUENCE MANY PERSONS AMONG THE GENTILES BECAUSE GENTILES ALREADY WERE UNDER HIS INFLUENCE THROUGH HIS VAST SYSTEM OF IDOLATRY. WE HAVE NO SUCH EXCUSES; WE WHO HAVE A NEARLY PERFECT GREEK TEXT OF THE NEW TESTAMENT. WE ESPECIALLY ARE RESPONSIBLE TO STUDY; WE WHO HAVE ALSO A WORD FOR WORD TRANSLATION INTO ENGLISH; EVEN THOUGH IT IS BY NO MEANS PERFECT.

AN INTRODUCTION TO THE HISTORY OF WESTERN EUROPE  
BY JAMES HARVEY ROBINSON, 1925

*Western Europe before the Barbarian Invasions* 19

The new religion, as it spread from Palestine among the Gentiles, was much modified by the religious ideas of those who accepted it. A group of Christian philosophers, who are known as the early fathers, strove to show that the Gospel was in accord with the aspirations of the best of the pagans. In certain ceremonies the former modes of worship were accepted by the new religion. From simple beginnings the church developed a distinct priesthood and an elaborate service. In this way Christianity and the higher forms of paganism tended to come nearer and nearer to each other as time went on. In one sense, it is true, they met like two armies in mortal conflict; but at the same time they tended to merge into one another like two streams which had been following converging courses.



ENCYCLOPEDIA JUDAICA, V.5, P.536

CHURCH, CATHOLIC.

Under the Roman Empire. While a Catholic (i.e., "universal") Church came into being only at The Council of Nicaea in 325, a unified interpretation of the new religion of \*Christianity had begun to emerge during the three preceding centuries, and concomitantly the foundations of a Church attitude toward the Jews. The early \*Church Fathers, eager to complete the break with the synagogue, urged the substitution of Sunday for the Jewish Sabbath and the abandonment of Passover, commemorative of the Exodus, for Easter, commemorative of the crucifixion. Retaining the Bible while denying the people that was its subject, the Church declared itself the New Israel. It claimed the patriarchs and prophets for itself and later pronounced Judaism an aberration from the Divine Will. All warnings and rebukes contained in the Jewish scriptures were applied to the Jewish people, while all praise and promise were applied to the Church. At the Council of Nicaea, Christianity was unified under the Roman emperor, whose favorite theologian at any given time set the standard for orthodoxy. Others were declared heretics and suffered worse persecution than did the Jews.

Church, and therefore imperial, policy to eliminate Judaism as a rival remained unchanged, except during the two-and-a-half years under \*Julian the Apostate (361-63). Under Church influence, the emperors forbade the conversion of pagans to Judaism. Slave ownership by Jews was made difficult and was completely outlawed if the slave were a Christian. Despite pronouncements of official protection, synagogues were frequently attacked and destroyed. On the other hand, the emperors pursued the traditional Roman policy of protecting Jewish life and the undisturbed practice of Judaism.

The attitudes expressed in the theological literature of the time were ultimately even more important. \*Eusebius of Caesarea took every opportunity to stress God's "rejection" of the Jewish people. \*John Chrysostom hurled bitter invective at the Jews and denounced Christians who associated with them and visited synagogues. \*Jerome delighted in emphasizing the faults, real or imagined, of ancient and contemporary Jews. Most important was \*Augustine, bishop of Hippo in North Africa. He put forward the theory, which long remained part of Christian theology, that it was the will of God to keep a remnant of the Jews alive in a degraded state as living witnesses of the Christian truth.



BY THE YEAR 200 A.D. IT HAS BEEN ESTIMATED THAT THERE WERE ABOUT 10,000 CHRISTIANS IN ROME WHICH HAD A POPULATION OF ABOUT 1,000,000. IN 258 A.D. THE "POPE", SIXTUS II, TOGETHER WITH 7 DEACONS WERE BEHEADED DURING EMPEROR VALERIAN'S PERSECUTION. THE 6TH WORLD POWER, ROME, WAS STILL RULING. THE ADVERSARY WAS STILL VERY MUCH IN AUTHORITY. THE DRAGON'S TRANSFER OF AUTHORITY INTO THE 7TH WORLD POWER WAS MADE VERY SLOWLY AT FIRST. THE LATIN LANGUAGE HAD BEEN ESTABLISHED IN THE CHURCH BY 230 A.D.

UNDER THE EMPEROR DIOCLETIAN, 296-304 A.D., THE CHURCH SUFFERED THE 10TH, AND FINAL PERSECUTION OF THE SMYRNA PROPHECY. THE TRANSFER OF THE ADVERSARY'S AUTHORITY INTO THE CHURCH BECAME MORE APPARENT. THE ROMAN EMPEROR CONSTANTINE CALLED THE COUNCIL OF NICAEA IN 325 A.D. THE SERPENT HAD DONE HIS WORK, NOW THINGS WERE READY FOR THE TRANSFER OF THE DRAGON'S AUTHORITY. THEODOSIUS I, (GIVEN BY GOD) EMPEROR OF ROME DECLARED CHRISTIANITY THE STATE RELIGION, FEB.27,380 A.D.

HALLEY'S BIBLE HANDBOOK, PAGE 770.

Sixtus III (432-440). The Western Empire was now rapidly dissolving amid the storms of the Barbarian Migration and, in the distress and anxiety of the times, Augustine wrote his monumental work, "The City of God," in which he envisioned a Universal Christian Empire. This book had vast influence in molding opinion favorable to a Universal Church Hierarchy under One Head. This promoted Rome's claim for Lordship.

Thus the Church was Changing its Nature, making itself over into the Image of the Roman Empire:

APOLOGETICS 33 AND 34 LIST ALL POPES AND ANTIPOPES.

AN ILLUSTRATED HISTORY OF THE POPES, M.J.WALSH, 1980, PAGE 65



Left: *The Greek word for chair is 'cathedra', and this gave its name to a cathedral, the place where a bishop has his seat. In early Christian churches the cathedra was usually placed against the curved end, or apse, of the building, with a bench on either side of it for the lower ranks of the clergy. The 'cathedra' shown here is in the church dedicated to Saint Gregory the Great in Rome, and is said to have been used by that pope (590-604). It is certainly possible, because the chair itself goes back beyond the time of Gregory.*

PERGAMOS REV.2:12 CT  
13. I-KNOW-ABSOLUTELY  
WHERE YOU ARE RESIDING;  
WHERE-IN-WHICH IS THE  
THRONE OF THE ADVERSARY.

THE FIRST REAL POPE

WITH THE MAJOR PERSECUTIONS OF CHRISTIANS ENDED, 304 A.D., AND THE COUNCIL OF NICAEA CALLED BY CONSTANTINE IN 325 A.D., THE SMYRNA PERIOD OF SUFFERING WAS ENDED. THE PERGAMOS (THOROUGHLY MARRIED) PERIOD WAS BEGINNING. THE ADVERSARY HAD NOT WON A VICTORY BY PERSECUTION, HE DECIDED TO JOIN THE CHURCH AND WORK FROM WITHIN THROUGH THE SERPENT.

REVELATION 12 CT

13 And when the dragon saw that he-was-cast into the earth, he-pursued the woman, one-who brought-forth the male.

14 And the two wings of-the eagle namely-the great one were-given to-the woman, in-order-that she-might-be-fly-ing into the wilderness into her place, where-in-which she-is-being-nourished there a season and seasons and half of-a-season from face of-the serpent.

15 And the serpent cast out-of his mouth behind the woman water as a river, in-order-that he-might-make her carried-off-by-the-river.

16 And the earth helped the woman, and the earth opened its mouth and swallowed the river which the dragon cast out-of his mouth.

17 And the dragon was-made-wroth over the woman, and he-went-away to-make war with the others of-her seed, the ones keeping the commandments of-the God and having the witness of Jesus.

IT IS VERY NECESSARY THAT A SERIOUS STUDENT REREAD THESE VERSES MANY TIMES.

THE PERIOD WHEN PAGANISM AND CHRISTIANITY BECAME "THOROUGHLY-MARRIED" IS VERY COMPLEX.

THE ADVERSARY'S THRONE WAS NOT ONLY IN ROME; IT WAS ALSO IN PERGAMOS. IT WAS AT THIS TIME HIS NAME ZEUS WAS BEING VENERATED IN THE GREEK SPEAKING WORLD.

SEE PAGES 16, 19, 21, AND THE PICTURE BELOW. ALSO APOLOGETICS 42 AND 24.

BRITANNICA, VOL.27, PAGE 68

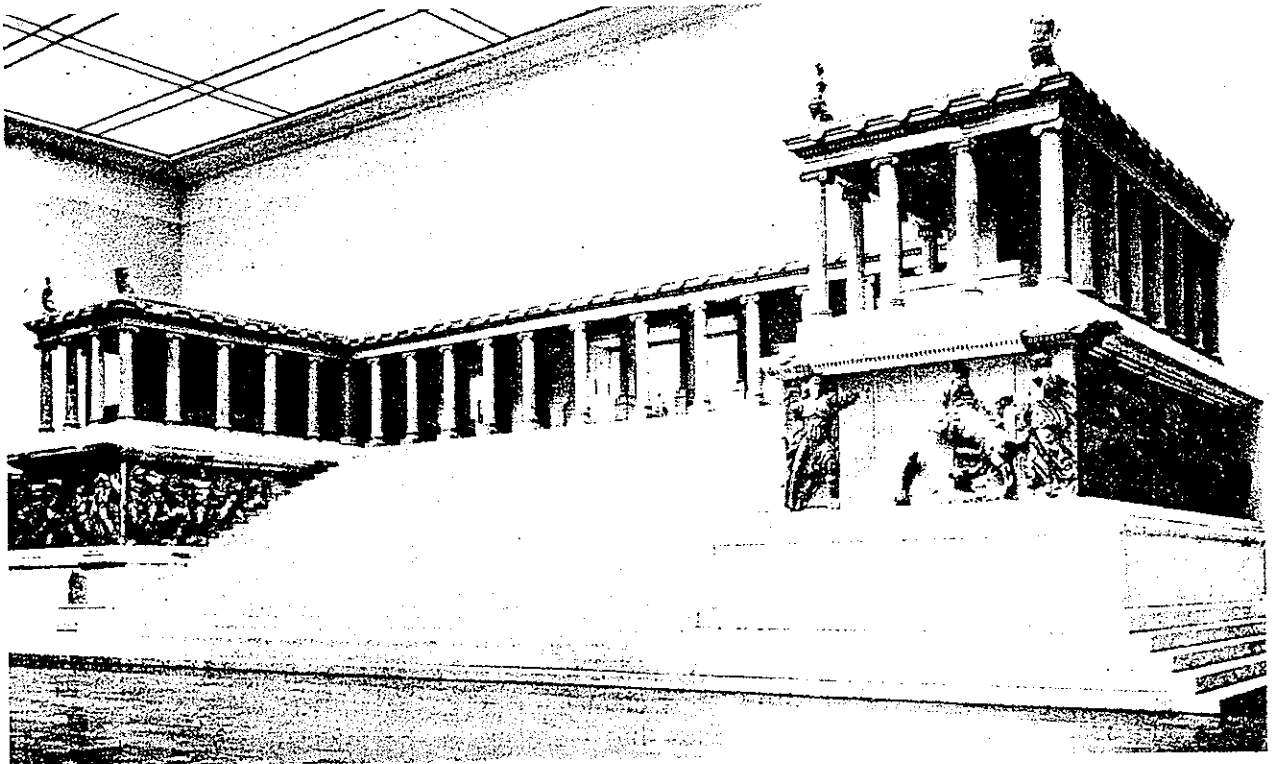

Figure 19: *Hellenistic relief sculpture.*

Great altar of Zeus at Pergamum. In the Staatliche Museen zu Berlin. (Left) Reconstruction of the west front.

THE PERGAMOS PERIOD LASTED TO ABOUT 750 A.D. REV. 12:13, THE DRAGON PURSUED THE WOMAN, ISRAEL. NOTICE THAT THE WOMAN WAS GIVEN "THE TWO WINGS OF THE GREAT EAGLE", TO BE FLYING INTO THE WILDERNESS. THE EAGLE, REFERS TO THE ROMAN EMPIRE. TWO WINGS; REMEMBER, DANIEL 2 PROPHESED THAT ROME WOULD BE A DIVIDED KINGDOM. REFER TO THE IMAGE WITH THE TWO LEGS. DURING THE PERIOD WHEN THE BARBARIANS WERE OVERRUNNING THE ROMAN EMPIRE BOTH THE ROMANS AND THE CHURCH WERE TOO BUSY TO DIRECTLY PURSUE THE JEWS. LEGAL STEPS WERE TAKEN TO RESTRICT THE JEWS, BUT VIOLENT PURSUIT OF THE JEWS CAME LATER. CONSIDER THE CHURCH COUNCILS. EVEN THESE SHOULD MAKE YOU DOUBT THAT THE "CHURCH" WAS REALLY "CHRISTIAN".

#### ENCYCLOPEDIA JUDAICA VOL.5, P.546

Many councils—diocesan, provincial, national, and ecumenical—have dealt with matters that concerned the Jews. The very first ecumenical council, that of Nicaea (325), called primarily for the purpose of defining the nature of Jesus, also had before it the problem of transferring the day of rest from the Jewish Sabbath to the Christian Sunday, a problem not solved for a long time after. Even before Nicaea, a council in Elvira (Spain) in c. 305 had tried to keep Jews and Christians apart by ordering the latter not to share a meal with Jews, not to marry Jews, not to use Jews to bless their fields, and not to observe the Jewish Sabbath. These objectives remained constant for centuries. For example, the prohibition against sharing a meal with Jews was repeated at Vannes (465), Epaon (517), Orleans III (538), Mâcon (583); mixed marriages were prohibited at Orleans II (533), Clermont (535), Orleans III (538), Orleans IV (541). As Jews entered commerce, pagan and Christian slaves became a subject for conciliar legislation. The trade in slaves was not forbidden, but Jews were forbidden to own Christian slaves and, especially, not to convert any slave to Judaism. These prohibitions were enacted and repeated at Orleans III (538), Orleans IV (541), Mâcon (583), Mâcon (626-27), Rome (743), Meaux and Paris (845-46), and— with less frequency—even later, down to the period of the Crusades.

In the meantime, a series of councils held at Toledo, Spain, during the seventh century adopted the more radical goal of seeking to uproot Judaism entirely. King Reccared (586-601) of Visigothic Spain, after he had abandoned the Arian heresy in favor of Catholicism, gained the complete support of the bishops.

#### AN INTRODUCTION TO THE HISTORY OF WESTERN EUROPE, J.H.ROBINSON, P.32

A long period of gloom now begins. Between the time of Theodoric and that of Charlemagne three hundred years elapsed, during which scarcely a writer was to be found who could compose, even in the worst of Latin, a chronicle of the events of his day.<sup>1</sup> Everything conspired to discourage education. The great centers of learning — Carthage, Rome, Alexandria, Milan — were partially destroyed by the barbarians or the Arabs. The libraries which had been kept in the temples of the gods were often annihilated, along with the pagan shrines, by Christian enthusiasts, who were not sorry to see the heathen literature disappear with the heathen religion.

At Toledo III (589), it was decreed that children of a mixed marriage had to be Christians, that Jews could not be appointed to positions of authority, i.e., hold public office, and were not permitted to circumcise their slaves. These blows at the social and economic position of the Jews were not enforced by Reccared's immediate successors. King Sisebut (612-620), however, not only reintroduced these laws, but decreed for the Jews of Spain either conversion or exile. Perhaps under the influence of \*Isidore of Seville, his successor King Swinithila rescinded the decree and even permitted the converts to revert to Judaism. But reaction came at Toledo IV (633). While condemning conversion by actual force, the council also condemned a return to Judaism. It dissolved mixed marriages, reinstated the regulation against Jews holding public office, applying this even to the descendants of Jews, and forbade slave-holding by Jews. A circumcised slave gained his freedom without compensation to his owner. This attempt at the total solution of the Jewish problem was reinforced at Toledo VI (638) which confirmed the expulsion from the country of the persistent Jews and ordered those already converted to make public confession of their adherence to Christianity. In 653, Toledo VIII reaffirmed all this legislation, as did Toledo IX (655), arranging for the converts to remain under the watchful eye of local priests and bishops. Yet in 681 King Erwig was still complaining (at Toledo XII) that there were Jews in his kingdom, and the council gave him even more authority. Finally, Toledo XVII (694) capped the series of laws by reducing to slavery all those in the Visigothic kingdom still found to be practicing Judaism. Their children were to be taken away to be brought up by Christians and to be married off to Christians. Property owned by declared or suspected Jews was confiscated. Only the Muslim conquest of Spain (711) restored Jewish life there.

#### THEODORIC, 454-526 A.D.

#### ENCYCLOPEDIA JUDAICA VOL.5, P.354

\*CHARLEMAGNE (742-814), king of the Franks from 768, emperor of the West from 800. Charlemagne was well disposed toward the Jews. A Jew, \*Isaac, was a member (probably interpreter) of the delegation he sent to the caliph Harun al-Rashid. He was the only one to return from Baghdad, and brought back an elephant, Rashid's gift to the emperor. Charlemagne also had dealings with Jewish merchants, especially with an expert in jewelry. Some of his legal provisions were clearly influenced by the theological issues of his day. Thus he forbade the Jews to employ Christians to work on Sundays and Christian festivals, and warned against the sale of church property to the Jews.

THE THYATIRA PERIOD NOW BEGAN. THIS COURSE IS NOT PRIMARILY INTERESTED IN THE CHURCH HISTORY; CHURCH HISTORY HAS BEEN TREATED IN VARIOUS APOLOGETICS. WE NEED TO PARTICULARLY SEE THE CHURCH IN RELATION TO THE JEWS. THIS CHURCH PERIOD WILL CONTINUE UNTIL THE RETURN OF JESUS. THE ADVERSARY IS ACTIVE IN THIS PERIOD. THE JEWS WERE SCATTERED, AND SOMEWHAT PROTECTED, DURING THE TIME PAGANISM AND CHRISTIANITY WERE BEING "THOROUGHLY-MARRIED". THE DRAGON NOW "WENT-AWAY TO-MAKE WAR" WITH ISRAEL'S SEED THAT FOLLOWED THE TORAH AND AT THE SAME TIME WERE WITNESSES OF THE FACT THAT JESUS WAS THE MESSIAH. (SEE REV.12:13-17, PAGE 5). MANY JEWS WERE IN THE CHURCH. WE MUST FOLLOW SOME CHURCH HISTORY TO UNDERSTAND THAT THE ADVERSARY NOW CONTROLLED THE 7TH WORLD POWER, THE "CHURCH". THIS EMPIRE WAS FAR FROM BEING "CHRISTIAN".

### THE ROMAN EAGLE

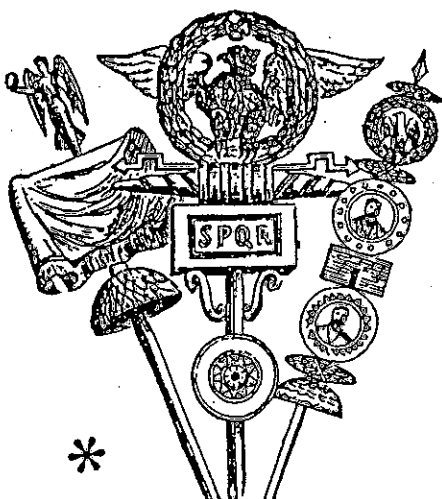

\* Roman Standards. (After Fairbairn.)

### REVELATION 2 CT

18 And to-the messenger of-the assembly in Thyatira you-write: These-things-here the son of-the God, *namely*-the *one* having his eyes as a flame of-fire, and his feet like to-chalcolibanus is-saying:

20 BUT I-am-holding down-upon you that you-are-let-ting-be the woman Jezabel, namely-the one saying herself a prophetess, and she-is-teaching and she-is-leading- astray my slaves to-commit-prostitution and to-eat idola- trous-sacrifices;

24 But to-YOU I-am-saying, *namely* to-the-others, *namely-to-the ones* in Thyatira, as-many-as are not holding this doctrine, they-who came not to-know the deep *things* of-the adversary, as they-are-saying: I-am not casting on YOU another weight;

25 Further which-*thing* YOU-are-holding, YOU-retain until I-might-be-present.

### HALLEY'S BIBLE HANDBOOK, PAGE 771 ETC.

Stephen II (752-757). At his request, Pepin led his army to Italy, conquered the Lombards, and gave their lands, a large part of Central Italy, to the Pope.

This was the beginning of the PAPAL STATES, or TEMPORAL DOMINION of the Popes. Civil Control of Rome and Central Italy by the Popes, thus established by Popes Zacharias and Stephen, and recognized by Pepin (754), was later confirmed by Charlemagne (774). Thus, Central Italy, once the Head of the Roman Empire, later a Gothic Kingdom ruled by the "Head" of the Church. This TEMPORAL KINGDOM of the Church lasted 1100 years, till 1870, when, on the outbreak of the war between France and Germany, king Victor Immanuel of Italy took possession of Rome, and added the Papal States to the Kingdom of Italy.

Up to 869 all Ecumenical Councils had been held in or near Constantinople, and in the Greek language. But now at last the Pope's in-sistent claim of being Lord of Christendom had become unbearable, and the East definitely separated itself. The Council of Constantinople (869), was the Last Ecumenical Council. Henceforth the Greek Church had its Councils, and the Roman Church had its Councils. And the Breach grew wider with the centuries. The brutal treatment of Constantinople by the armies of Pope Innocent III during the Crusades embittered the East all the more.



THE SYNAGOGUE OF THE ADVERSARY IN CONTROL, PAGE 32.  
CONDITIONS IN THE 7TH WORLD EMPIRE.  
 NO ONE WAS "CASTING OUT SATAN".

CONTINUING HALLEY'S BIBLE HANDBOOK.

Adrian II (867-872). John VIII (872-882). Marinus (882-884). With these Popes began the Darkest Period of the Papacy (870-1050). The 200 years between Nicolas I and Gregory VII is called by historians the MIDNIGHT OF THE DARK AGES. Bribery, Corruption, Immorality and Bloodshed, make it just about the Blackest Chapter in the Whole History of the Church.

Sergius III (A.D. 904-911). Said to have had a mistress, Marozia. She, her mother Theodora, and her sister, "filled the Papal chair with their paramours and bastard sons, and turned the Papal Palace into a den of robbers." Called in history The Rule of the Harlots (904-963).

Anastasius III (911-913). Lando (913-914). John X (914-928), "was brought from Ravenna to Rome and made Pope by Theodora for the more convenient gratification of her passion." He was smothered to death by Marozia, who, then, in succession, raised to the Papacy Leo VI (928-929), and Stephen VII (929-931), and John XI (931-936), her own illegitimate son. Another of her sons appointed the four following Popes, Leo VII (936-939), Stephen VIII (939-942), Martin III (942-946), and Agapetus II (946-955). John XII (955-963), a grandson of Marozia, was "guilty of almost every crime; violated virgins and widows, high and low; lived with his father's mistress; made the Papal Palace a brothel; was killed while in the act of adultery by the woman's enraged husband."

Boniface VII (984-985), murdered Pope John XIV, and "maintained himself on the blood-stained Papal Throne by a lavish distribution of stolen money." The Bishop of Orleans, referring to John XII, Leo VIII and Boniface VII, called them "monsters of guilt, reeking in blood and filth; Antichrist sitting in the Temple of God."

John XIX (1024-1033), Bought the Papacy. He passed through all the necessary clerical degrees in one day.

Benedict IX (1033-1045), was made Pope as a boy 12 years old, through a money bargain with the powerful families that ruled Rome. "Surpassed John XII in wickedness; committed murders and adulteries in broad daylight; robbed pilgrims on the graves of martyrs; a hideous criminal, the people drove him out of Rome." Some call him the Worst of all the Popes.

Gregory VI (1045-1046), Bought the Papacy. Three rival Popes: Benedict IX, Gregory VI, Sylvester III. "Rome swarmed with hired assassins; virtue of pilgrims was violated."

Victor III (1086-1087). Urban II (1088-1099), continued war with the German Emperor. Became leader in the Crusade Movement, which added to Papacy's Leadership.

Innocent III (1198-1216). Most Powerful of all the Popes. Claimed to be "Vicar of Christ," "Vicar of God," "Supreme Sovereign over the Church and the World." Claimed the right to Depose Kings and Princes; and that "All things on earth and in heaven and in hell are subject to the Vicar of Christ."

IT IS BECAUSE SO MANY NOMINAL "CHRISTIANS" REFER TO THE ROMAN ECUMENICAL ASSEMBLY, THE 7TH WORLD POWER, AS A CHRISTIAN CHURCH THAT HISTORIANS INCORRECTLY BLAME CHRISTIANS FOR MANY EVIL ACTIONS WHICH SHOULD BE ATTRIBUTED TO GOD'S ADVERSARY. REMEMBER ON PAGE 2 WE SAW THAT THE ADVERSARY IS LEADING ASTRAY THE TOTAL INHABITED EARTH; THAT IS, THE ROMAN ECUMENICAL ASSEMBLY. WE WILL LEARN HOW THE DRAGON INCREASED HIS EFFORT TO DESTROY THE JEWS, REALIZING THAT HIS TIME IS RUNNING OUT.

ENCYCLOPEDIA JUDAICA, VOL. 5, P. 537

The weakening of Pope Gregory I's policy was exemplified when Pope Leo VII (937) advised the archbishop of Mainz to expel the Jews from his diocese if they continued to refuse baptism.

One may conclude that, as the Church in the West grew stronger, its policy grew more hostile; but the economic position of the Jews continued to work in their favor.

**The Later Middle Ages.** During the crusading era, the situation of the Jews underwent radical changes. When the first Crusaders, unorganized peasants and city rabble, reached the Rhineland, they were already convinced that killing a Jew nearby was as meritorious as killing a Muslim in distant Palestine—and much less dangerous.



Jews in the synagogue of Trent, depicted wearing the Judenhut (Jew's hat) and allegedly plotting to "slaughter" a Christian child for "ritual" purposes. (From *History of the Murdered Christian Child in Trent, Germany, 1475.*)

THESE PICTURES ARE TAKEN FROM "THE BOOK OF JEWISH KNOWLEDGE", PAGE 499. 1964 BY NATHAN AUSUBEL

Driven out of commerce during the 12th century by the rise of a middle class in the towns, the Jews turned to moneylending, especially since the Church prohibited the taking of interest by Christians. Churchmen, high and low, now joined the popular outcry against the Jews as extortioners ruining the Christian population. The hostility thus engendered resulted in the invention of charges which plagued the Jews for many centuries. The \*blood libel first appeared in the 12th century, and that of the desecration of the \*Host in the 13th. A number of popes, then and later, denied these accusations, but they continued to crop up in various localities and resulted in the torture and killing of many Jews, since the local clergy were rarely restrained by the expressions of papal doubt. Contact between Christians and Jews being considered dangerous, Pope \*Innocent III (1215) imposed upon all Jews the obligation of wearing distinguishable garments, and this soon developed into the Jewish \*badge.



Varieties of the Judenhut (Jew's hat) compulsory for Jews during the Middle Ages by decree of the Lateran Council in 1215. (From H. Weiss's *Kostumkunde.*)



Yellow badge compulsory on outer garment of Jews. Rhineland, end of 16th century.

LET US LOOK AT ANOTHER EXAMPLE OF HOW THE SERPENT PROGRAMS THE BIBLE TRANSLATORS TO HELP HIDE THE ADVERSARY'S OPERATIONS. IN THIS CASE A PROPHECY, ALREADY FULFILLED, IS MADE TO APPEAR AS STILL FUTURE.

## 2 THESSALONIANS 2

## Phillips Modern English

### King James Version

<sup>3</sup> Let no man deceive you by any means: for *that day shall not come*, except there come a falling away first, and that man of sin be revealed, the son of perdition; <sup>4</sup> Who opposeth and exalteth himself above all that is called God, or that is worshipped; so that he as God sitteth in the temple of God, shewing himself that he is God.

### Living Bible

<sup>3</sup> Don't be carried away and deceived regardless of what they say.  
For that day will not come until two things happen: first, there will be a time of great rebellion against God, and then the man of rebellion will come—the son of hell. <sup>4</sup> He will defy every god there is, and tear down every other object of adoration and worship. He will go in and sit as God in the temple of God, claiming that he himself is God.

### Today's English Version

<sup>3</sup> Do not let anyone fool you in any way. For the Day will not come until the final Rebellion takes place and the Wicked One appears, who is destined to hell. <sup>4</sup> He will oppose everything which men worship and everything which men consider divine. He will put himself above them all, and even go in and sit down in God's temple and claim to be God.

### New International Version

<sup>3</sup> Don't let anyone deceive you in any way, for [that day will not come] until the rebellion occurs and the man of lawlessness is revealed, the man doomed to destruction. <sup>4</sup> He opposes and exalts himself over everything that is called God or is worshiped, and even sets himself up in God's temple, proclaiming himself to be God.

Don't let anyone deceive you by any means whatever. That day will not come before there first arises a definite rejection of God and the appearance of the lawless man. He is the product of all that leads to death, and he sets himself up in opposition to every religion. He even takes his seat in the Sanctuary of God, to show that he really claims to be God.

### Revised Standard Version

<sup>3</sup> Let no one deceive you in any way; for that day will not come, unless the rebellion comes first, and the man of lawlessness is revealed, the son of perdition, <sup>4</sup> who opposes and exalts himself against every so-called god or object of worship, so that he takes his seat in the temple of God, proclaiming himself to be God.

### Jerusalem Bible

<sup>3</sup> Never let anyone deceive you in this way.  
It cannot happen until the Great Revolt has taken place and the Rebel, the Lost One, has appeared. <sup>4</sup> This is the Enemy, the one who claims to be so much *greater than all* that men call "god," so much greater than anything that is worshiped, that he enthrones himself in God's sanctuary and claims that he is God.

### New English Bible

Let no one deceive you in any way whatever. That day cannot come before the final rebellion against God, when wickedness will be revealed in human form, the man doomed to perdition. He is the Enemy. He rises in his pride against every god, so called, every object of men's worship, and even takes his seat in the temple of God claiming to be a god himself.



★ NOTE THE EXPRESSIONS USED TO TRANSLATE THE WORD "APOSTASIA". ALL 3 OF MY INTERLINEARS TRANSLATE THIS WORD BY THE ENGLISH WORD "APOSTASY". THESE TRANSLATORS USE: "FALLING AWAY", GREAT REBELLION AGAINST GOD, THE FINAL REBELLION, THE REBELLION, DEFINITE REJECTION, THE REBELLION, THE GREAT REVOLT, THE FINAL REBELLION AGAINST GOD. THE KING JAMES IS THE ONLY ONE THAT IS EVEN CLOSE. THESE ALL GIVE AN ALTOGETHER FALSE RENDERING. THIS APOSTASY REFERS TO THE APOSTASY FROM THE LAWS OF GOD THROUGH MOSES; FORCED UPON THE JEWS BY THE ADVERSARY IN THE 7TH WORLD EMPIRE. THIS IS ALREADY HISTORY.

● CONSIDER THE TITLES GIVEN THIS MAN: MAN OF SIN, MAN OF REBELLION, WICKED ONE, MAN OF LAWLESSNESS, LAWLESS MAN, MAN OF LAWLESSNESS, THE REBEL, WICKEDNESS. COMPARE THESE TO THE CONSISTENT TRANSLATION.

\* WHEN HE CLAIMS TO BE GOD; WHERE DOES HE SIT? SIX SAY "TEMPLE" AND TWO SAY "SANCTUARY". "TEMPLE" IS ABSOLUTELY WRONG. "TEMPLE" MAKES US WAIT FOR THE REBUILDING OF THAT TEMPLE. "SANCTUARY" IS USED IN ALL CASES BY PAUL TO REFER TO THE "BODY" OF BELIEVERS. SEE THE TEACHING DICTIONARY, PAGE 195. ALL THIS WAS UNDERSTOOD AND SHOWN TO BE FULFILLED BY A PAINTING DONE BY ALBRECHT DURER IN 1511.



ROMANISM AS IT IS, 1876, P.125

In the 4th session of the 5th Lateran council, December 10, 1512, and with the approbation of the council, Christopher Marcellus thus publicly addressed the pope in the name of the church: "Thou art pastor, thou physician, thou governor, thou supporter, thou in fine another God on the earth." According to Innocent III, "the pope holds the place of the true God." The canon law, in the gloss, denominates the pope "our Lord God"; and the canonists say that "the pope is the one God, who has all power in heaven and in earth." The canon law also declares that "the pope has the plenitude of power and is above right;" "he changes the substantial nature of things, for example, by transforming the unlawful into lawful."

II THESSALONIANS 2 CT

3 Might not anyone delude YOU according to not one manner; because *that day will not come* if not the apostasy might-come firstly and the MAN of-the lawlessness might-be-uncovered, the son of-the destruction,

4 The *one* opposing and being-exceedingly-lifted-up over every-thing being-called God or venerated-object, so-that he to-seat with-reference-to the sanctuary-of-the God, pointing-out himself that he-is god.

← POPE JULIUS II (1503-1513)  
APOLOGETICS 42, PAGE 13.



**REFER BACK TO PAGE 38. POPE URBAN II BECAME THE LEADER OF THE CRUSADE MOVEMENT. I HAVE TAKEN A FEW STATEMENTS FROM JUDAICA VOL. 5 TO BRING TO YOUR ATTENTION THE PLIGHT OF THE JEWS IN THIS PERIOD OF HISTORY.**

CRUSADES, military expeditions of the European Christians in the 11th, 12th, and 13th centuries to conquer Erez Israel from the Muslims or to repel their counterattacks.

The community of \*Mainz was more troubled about the French communities and thought that those in the Rhineland had no reason for concern on their own account. However, their sense of security was soon to be brutally shaken shortly after the first muster of the crusaders and before the Jewish communities of Germany could take whatever precautions were open to them. The sight of the wealthy Rhenish communities acted as an incentive to the crusaders, who decided to punish "the murderers of Christ," wherever they passed, before their encounter with their official enemies, the Muslims. Soon it was rumored that Godfrey of Bouillon himself had vowed that he would not set out for the Crusade until he had avenged the crucifixion by spilling the blood of the Jews, declaring that he could not tolerate that even one man calling himself a Jew should continue to live.

It was in the region where the crusaders assembled that violence broke out, in the weeks between Passover and Shavuot. The rioting continued until Tammuz (June-July). On the eighth of Iyyar (May 3, 1096), the crusaders surrounded the synagogue of \*Speyer; unable to break into it, they attacked any Jews they could find outside the synagogue, killing eleven of them. One of the victims, a woman, preferring death to conversion, the only choice left open by the crusaders, inaugurated the tradition of freely accepted martyrdom. \*Kiddush ha-Shem, martyrdom for the glory of God, thus became the exemplary answer of Jews threatened in their life and faith by the crusaders. On the 23rd of Iyyar (May 18, 1096) \*Worms suffered a similar fate. The crusaders first massacred the Jews who had remained in their houses, then, eight days later, those who had sought an illusory refuge in the bishop's castle. The victims numbered about 800; only a few accepted conversion and survived, the great majority choosing to be killed or suicide rather than apostasy.

At \*Regensburg, all the Jews were dragged to the Danube where they were flung into the water and forced to accept baptism. At \*Metz, \*Prague, and throughout \*Bohemia, one massacre followed another.

THE CRUSADES IN EREZ ISRAEL. Meanwhile, the crusaders had reached \*Jerusalem (June 7, 1099), and the siege had begun. The city was captured on July 15, with Godfrey entering it through the Jewish quarter, where inhabitants defended themselves alongside their Muslim neighbors, finally seeking refuge in the synagogues, which were set on fire by the attackers. A terrible massacre ensued: the survivors were sold as slaves, some being later redeemed by Jewish communities in Italy.

As early as the summer of 1146, a Cistercian monk, Radulph, while preaching the Crusade, violently attacked the Jewish communities of the Rhineland, exhorting the crusaders to avenge themselves on "those who had crucified Jesus" before setting out to fight the Muslims.

**The Third Crusade and After.** In \*England, the Third Crusade had the most savage repercussions. England had taken little interest and no part in the first two Crusades, but her zeal was none the less intense when Richard the Lion-hearted decided to take part in person in the third. In January the first abuses struck the port of \*Lynn, where the bulk of the Jewish community was massacred. The same occurred in \*Norwich and \*Stamford. At \*Lincoln, the Jews were saved through the intervention of royal agents. The worst outrage took place in \*York, where a number of local nobles, in heavy debt to the Jews, seized the opportunity to rid themselves of their burden. When attacked, the Jews took refuge in the Castle Keep, which the guard had opened for them; those who remained in the town were slaughtered. On their refusal to allow access to the keep, the Jews were besieged. On March 16, on the eve of Passover, the rabbi, \*Yom Tov b. Isaac of Joigny, realizing that all hope was lost, asked his brethren to choose suicide rather than submit to baptism. First setting fire to their possessions, one after the other killed himself. More than 150 died in this way, and the few survivors were murdered by the mob.

**The Significance of the Crusades.** In the memory of the Jews, the Crusades became the symbol of the opposition between Christianity and Judaism, and the tension aroused by the persecutions was far more severe than that which had existed since the origins of Christianity. The debate ceased to be a theological one, to the extent that this had ever been the case. The Christians saw the Jews as the implacable enemies of their faith and in this climate the \*blood libel became widespread. From the 12th century comes the first expression of the idea of a Jewish plot against the Christian world: it was alleged that the Jews had to sacrifice one Christian each year, and held an annual council to decide the site of the sacrifice and the name of the victim. At \*Blois in 1171, all members of the Jewish community were burned at the stake following such an accusation, and from the 13th century similar charges were raised in Germany.

The Jewish community found a source of inspiration in the memory of the martyrs. There being no hope of immediate vengeance, the massacre of the innocents was glorified and compared to the sacrifice of Isaac. The suicide of the martyrs was seen as a collective act for the sanctification of the Divine Name. Rather than a bitter memory of cruel affliction, it became an example of true piety and submission to the will of God. For the succeeding generations the martyrs were an object of admiration and even of envy, for they had been the generation whom God had put to the test and they had proved themselves worthy.

**POPE INNOCENT III (1198-1216, PAGE 38) DECREED TRANSUBSTANTIATION. THIS DOCTRINE TEACHES THAT THE BREAD AND WINE OF THE "THE LORD'S SUPPER" ARE TRANSFORMED INTO THE BODY AND BLOOD OF CHRIST, ALTHOUGH THEIR APPEARANCE REMAINS THE SAME.**

THIS IS ANOTHER ONE OF THE SERPENT'S FALSE TEACHINGS THAT COULD BRING GREAT HARM TO THE JEWS. PAGAN INFLUENCE LED TO THIS SUPERSTITION AND BROUGHT MANY PEOPLE UNDER THE 7TH WORLD EMPIRE.

### ENCYCLOPEDIA JUDAICA, V8.P.1040

HOST, DESECRATION OF, alleged profanation of the wafer consecrated in the Roman Catholic ceremony of the Eucharist, and believed in the Catholic doctrine of Transubstantiation to become thereby the actual body of Jesus. The doctrine was first officially recognized at the Fourth Lateran Council of 1215. After that period therefore it was widely held that in certain circumstances—for instance disbelief or desecration—the Host might show supernatural powers. At the same time, it was imagined in some Christian circles that the Jews, believing paradoxically (which they obviously could not if they remained Jews) that the consecrated wafer was in fact the very body of Jesus, desired to renew upon it and him the agonies of the Passion, by stabbing, tormenting, or burning it. Such was the intensity of their paradoxical hatred that they would not abandon their Jewish perfidy even if the sacred wafer manifested its indignation and its miraculous essence by shedding blood, emitting voices, or even taking to flight.

The first recorded case of alleged Desecration of the Host was at Belitz near Berlin in 1243, when a number of Jews and Jewesses were burned at the stake on this charge on the spot later known as the Judenbergr.

On the other hand, the most remarkable artistic representation of the Desecration of the Host was in the famous altar predella painted by Paolo Uccello (1397-1475) for the Confraternity of the Sacred Sacrament at Urbino, showing in successive panels the Jewish loan banker purchasing the wafer from a needy woman, his attempt to burn it, the miraculous manifestation that followed, and the subsequent terrible punishment by burning of the culprit—with his entire family (see vol. 3, cols. 103-106 of this Encyclopaedia). The Jews were expelled from England (1290) before the libel became widely spread; but there it received its reflection in the Croxton Sacrament Play, written long after the Expulsion (c. 1461).

Well-known incidents on the Continent were those of \*Paris in 1290, commemorated in the Church of the Rue des Billettes and in a local confraternity which long flourished; in \*Brussels (Enghien) in 1370, long celebrated in a special festivity and still in important artistic relics in the Church of St. Gudule, which led to the extermination of Belgian Jewry; at \*Deggendorf in Bavaria in 1337-38 which sparked off a series of massacres affecting scores of places in the region, still celebrated locally as the Deggendorf Gnad; at Knoblauch near \*Berlin in 1510 which resulted in 38 barbarous executions and the expulsion of Jews from Brandenburg (it was subsequently discovered that a common thief was responsible); at \*Segovia in 1415, said to have brought about an earthquake which resulted in the confiscation of the synagogue, the execution of leading Jews, and is still the occasion of the great local feast of Corpus Christi. The Infante Don Juan of Aragon took under his personal patronage allegations of the sort at \*Barcelona in 1367 (when some of the greatest Jewish scholars of the age, including Hasdai \*Crescas and \*Isaac B. Sheshet Perfet, were implicated) and in \*Teruel and \*Huesca ten years later.

The \*Marranos of Spain and Portugal were also popularly believed to continue the malpractice of their Jewish predecessors in this respect. When in 1671 the pyx with a consecrated host was stolen from the Church of Orivellas in Lisbon (by a common thief as subsequently transpired) the court went into mourning and an edict was signed banishing all \*New Christians from the country. Even in the 18th century, an Alsatian Jew was cruelly executed with others on a charge of desecrating the Host (Nancy 1761). The accusation was brought up in Rumania (Bislad) as late as 1836.

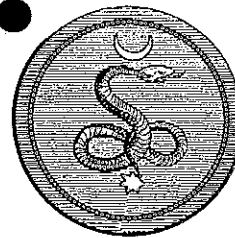

LARGE SIZE  
HOSPITAL PYX

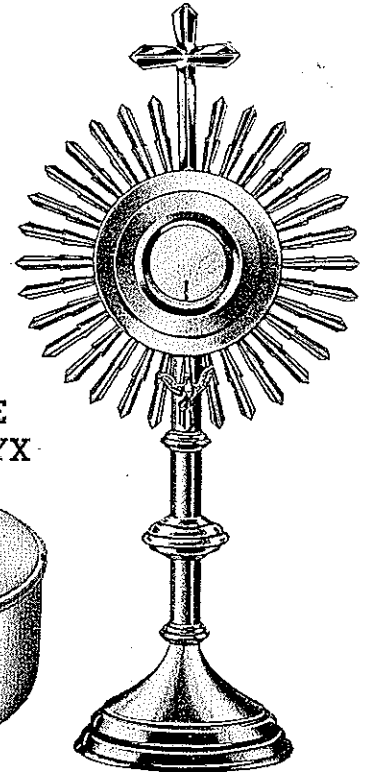
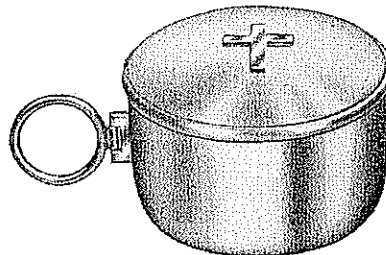

No. 150—OSTENSORIUM

### SYMBOLS SIGNS & SIGNETS, LEHNER 1950

- THE SKY SERPENT, EGYPTIAN
- ★ JOTMA—THE MIGHT, VEDIC-HINDU





German broadsheet, c. 1480, telling the story of the alleged desecration of the Host in Passau, Bavaria, in 1478.

1. Christoff Eisengreisshamer, a Christian, steals eight consecrated wafers from St. Mary's Church.
2. He sells them to Jews, who are identified by their circular badge, for one gulden.
3. The Jews take the Host to the synagogue.
4. In reenactment of the crucifixion they stab the wafers, out of which blood flows.
5. They send some of the wafers to Prague and Salzburg.
6. When they try to burn the remaining wafers, on which the face of a child has appeared, two angels and two doves fly out of the oven.
7. The Passau Jews who have taken part in the desecration are arrested.
8. They are tried and found guilty, and two are beheaded.
9. Others are tortured with burning pincers and then burnt.
10. All the Jews who knew of the desecration are burnt to death.
11. Christoff is torn to pieces with glowing pincers.
12. The synagogue is turned into a church.

**THE 7TH WORLD POWER EXERTS A GREAT DEAL OF INFLUENCE THROUGH THE EUCHARIST, COMMUNION, OR SO-CALLED "LORD'S SUPPER". THE LORD INSTITUTED "THE PASSOVER" FEAST AS THE MEMORIAL OF HIS DEATH. THE PHRASE, "THE LORD'S SUPPER", IS NOWHERE IN THE GREEK TEXT. THE "CHURCH" DID NOT REPLACE THE PASSOVER WITH THE EUCHARIST UNTIL 325A.D. AT THIS TIME THE SO-CALLED "CHURCH" HAD BEEN FILLED WITH PAGANS AND WAS TOTALLY UNDER CONTROL OF THE ADVERSARY.**

**I BELIEVE THAT TO PARTAKE OF THE EUCHARIST IS A SORT OF ENROLLMENT INTO THE 7TH WORLD POWER. YOU WOULD DO WELL TO READ FOX'S BOOK OF MARTYRS. IT WAS ANTISEMITISM, HATRED OF THE JEWS, THAT BROUGHT ABOUT THIS CHANGE. REMEMBER, JEHOVAH GAVE ALL SCRIPTURE BY HIS CHOSEN PEOPLE THE JEWS. EVERYTHING YOU KNOW OR CAN KNOW ABOUT GOD COMES THROUGH THESE PEOPLE, HIS OWN POSSESSION, PAGE 18.**

**1 CORINTHIANS 11 KJ**

20 When ye come together therefore into one place, *this* is not to eat the Lord's supper.

**I CORINTHIANS 11 CT**

20 Therefore of-YOU coming-together on the same *thing* it-is not to-eat a lordly supper;

THE RIVER OF ANTISEMITISM WAS RISING UNDER THE PRESSURE FROM THE 7TH WORLD EMPIRE. THE PERIOD OF THE INQUISITION WAS DIRECTED AGAINST JEWS AND MANY CHRISTIANS THAT THE DRAGON CALLED HERETICS.

I HAVE PLACED SMALL PORTIONS OF THE ARTICLE ON THE INQUISITION IN JUDAICA. YOU WILL NOTICE THAT THOSE WHO ENACTED THESE LAWS ARE THE SAME TYPE OF CRUEL DESPOTS AS NERO AND THE OTHER TYRANTS THAT HAD PREVIOUSLY PERSECUTED BOTH JEWS AND CHRISTIANS. IF YOU ARE HONEST THERE IS NO WAY YOU CAN PUT THE POPES IN ANY OTHER CLASS THAN OTHER MINISTERS OF THE ADVERSARY. READ THE FOLLOWING ARTICLES CAREFULLY AND YOU WILL NEVER CALL THE 7TH WORLD EMPIRE A CHRISTIAN COMMUNITY.

The Early Institution. Although the Inquisition was established by Pope \*Gregory IX, it owed its name to the procedure instituted by Pope \*Innocent III (1198-1216) for searching out persons accused of heresy. Gregory himself created permanent judges delegate (*inquisitores dati ab ecclesia*) in 1233, entrusting the mission of judging heretics to the \*Dominicans, who divided their duties with the \*Franciscans on a geographical basis. Life imprisonment was prescribed for the repentant and capital punishment for the obdurate, after they were handed over to the secular authorities. The practice of burning heretics at the stake (see \*Auto-da-fé) was introduced in the last years of the 12th century. By 1255 the Inquisition was fully active in Central and Western Europe, but was never established in England and Scandinavia. Portugal was not included in the system until 1532. The use of torture for the detection of heresy was authorized in 1252 by Innocent IV (1243-54), and confirmed by Urban IV (1261-64). Property of those sentenced to life imprisonment or to death was handed over to the secular arm, but often the Church sought to derive some profit from the confiscated valuables.

Initially, the Inquisition dealt with Christian heretics, like the \*Albigenses, against whom a full-scale Crusade was organized in 1209. According to Canon Law, the Inquisition was not authorized to interfere in the internal affairs of the Jews, but this rule was abolished on the ground that the presence of Jews caused heresy to develop in the Christian milieu. The dispute which raged around Maimonides' books (1232) provided the Inquisition with a convenient opportunity to interfere in Jewish affairs (see \*Maimonidean controversy). In June 1242, an inquisitorial committee condemned the Talmud in Paris, principally for blasphemy against Jesus, and thousands of volumes of it were subsequently burned in public (see Burning of \*Talmud). The first mass burning of Jews on the stake took place in France in 1288, following a \*blood libel at \*Troyes. Nevertheless, persecution of the Jews by the Inquisition in France remained confined to a few cases, never reaching the proportions it later assumed in the Iberian Peninsula.

The Spanish Inquisition until 1492. The Spanish Inquisition, which began to function in 1481, far surpassed the papal Inquisition of the Middle Ages both in the scale and intensity of its activities. Its impact on Jewish history was incomparably greater, for its principal objective was the persecution of those inclined toward Judaism. Of the many scholars who have studied the nature of the Spanish Inquisition, some have emphasized its ecclesiastical character, while others have been inclined to regard it as a distinctly political institution. This Inquisition was in fact established as a Church institution deriving its authority from the pope, but it was destined to solve a specifically Spanish religious-social problem and thus evolved into a political institution, although retaining its purely religious aspect.

The persecutions of 1391 and of 1412-14 created a new religious and social problem in \*Spain, that of the \*anusim or Conversos. Having abandoned the Jewish faith under duress, these \*New Christians continued to maintain close relations with their former brethren and occasionally seized the opportunity to emigrate in order to return to Judaism. All attempts made by the authorities to separate the Conversos from Judaism---by legislation, by the separation of their dwellings from the Jewish quarters, or through education---were fruitless. From the second half of the 15th century, a public discussion took place on the question of the Conversos and various methods and projects were advanced for the solution of the problem.

Prominent among those who adopted a firm attitude against the Conversos was the Franciscan monk \*Alfonso de Espina (second half of the 15th century). In his work  *Fortalitium Fidei* (Nuremberg, 1485-98), he proposed a detailed plan for heresy-hunting among the Conversos, a scheme which might well be regarded as the harbinger of the establishment of the Spanish Inquisition. This debate was accompanied by violent outbursts against Conversos, the most important being the attempt by Pedro \*Sarmiento in Toledo in 1449 to institute Inquisition court-proceedings against Conversos who had risen to important functions within Christian society.

The ascent of \*Ferdinand and Isabella to the throne of Castile in 1474 provided a favorable opportunity for those Church extremists who advocated a radical solution. The Catholic monarchs required some faithful supporters for the consolidation of their rule, and these emerged from among the churchmen and the townspeople. In exchange for their support, Ferdinand and Isabella introduced a series of restrictive measures against both Conversos and Jews. However, there is no reason to doubt that the appeal of Ferdinand and Isabella to Pope Sixtus IV in 1477, requesting him to authorize them to establish the Inquisition, was motivated by the religious fervor which was characteristic of their policy from the start. In his reply given on Nov. 1, 1478, the pope authorized them to appoint inquisitors in every part of Castile.

Two Dominican monks, Miguel de Morillo and Juan de San Martín, were appointed to head the Inquisition on Sept. 27, 1480, and on Jan. 1, 1481, they began their activities, choosing to start in \*Seville because the region of Andalusia was considered an important center of Judaizers. The inquisitors demanded that the noblemen deliver into their hands all Judaizers who had fled and been taken under their protection. A large number of Conversos were arrested, including many wealthy and notable personalities of Seville. The records of the tribunal have not been preserved in this case, but from the evidence of the chronicler Andrés Bernaldez it appears that during the years 1481-88 over 700 Conversos were burned at the stake.

DO NOT LOOSE SIGHT OF THE FACT THAT THE PERSONS CARRYING OUT THESE ATROCITIES WERE MINISTERS OF SATAN. THESE WERE JUST FORE-RUNNERS OF THE ONES CARRYING OUT THE HOLOCAUST. CONTINUE READING, WATCH THE DATES VERY CAREFULLY.

and more than 5,000 were brought back to the Church by means of various penalties. In Aragon, the papal Inquisition which had been founded in 1237/8 under the influence of \*Raymond de Peñafort operated against the Conversos of Valencia during the 1460s. The results of its activities appeared unsatisfactory to the king, however, and as early as 1484 he appointed new investigators to take up their duties there.

Moved by the complaints of many Conversos against the methods of the Seville Inquisition, Pope Sixtus IV at first (January 1482) opposed the extension of the tribunal to Aragon, but was unable to hold out against Ferdinand's displeasure and, in October 1483, agreed to extend the rights of the Inquisition in Aragon, Catalonia, and Valencia. During that year, the Jews were expelled from Andalusia and Tomás de \*Torquemada, head of the Dominican monastery of Santa Cruz in Segovia, was appointed inquisitor-general of the Spanish kingdom. The measures he introduced determined the character of the institution from the start and left their imprint on its activities during the whole of its existence. It was he who decided on the composition of every Inquisition tribunal and abolished all the orders which had previously been issued by the pope in favor of the Conversos.

In 1483, an Inquisition tribunal, which continued until 1485, was set up in \*Ciudad Real. Torquemada intended this tribunal as an experiment in anticipation of the establishment of a tribunal in \*Toledo, to prepare the public and test their reactions. During this period at least 100 Conversos were condemned, 52 to the stake, about 15 in effigy, and the remains of others were exhumed and burned. An Inquisition tribunal was also established in \*Guadalupe in 1485, and during one year 52 Conversos were burned at the stake and the bodies of 48 condemned after death were exhumed and burned, as were the effigies of 25 Conversos who had fled.

The authorities compelled the communal leaders of the Jews to proclaim in the synagogues that any Jew knowing of Conversos who adhered to Judaism, who did not bring this to the cognizance of the Inquisition, would be laid under the \*herem. The tribunal of Toledo, which had jurisdiction over 88 towns and villages, brought many Conversos to trial during its early years, but by 1492 the number of trials gradually decreased, the Inquisition then being busy with preparations for the expulsion. In 1486, 20 autos-de-fé were held in Toledo and 3,327 persons sentenced: in 1488, there were three autos-de-fé in which 40 Conversos were burned at the stake and over 100 bodies exhumed and burned; in 1490, there were two autos-de-fé in which 422 Conversos were burned at the stake and 11 sentenced to life imprisonment;



**AUTO-DA-FÉ, "ACT OF THE FAITH", THE PUBLIC EXECUTION OF THESE "HERETICS?". ABOVE, THE PROCESSION OF THE INQUISITION OF GOA, IN PORTUGUESE INDIA. NOTE THE CATHOLIC CLERGY.**



I HAVE GREATLY LIMITED COMMENTS ON THE INQUISITION. RECORDS OF THESE EVENTS COULD FILL HUNDREDS OF VOLUMES. MY PRIMARY CONCERN IS FOR YOU TO REALIZE THAT THESE CRUELITIES ARE A CONTINUATION OF THOSE PRACTICED BY THE ROMAN EMPIRE AGAINST CHRISTIANS AND JEWS. THESE PERSECUTIONS LASTED ABOUT 600 YEARS, YET YOU SELDOM HEAR MUCH ABOUT THE INQUISITION. SMALL HANDS ARE USED TO POINT OUT SOME OF THE VERY IMPORTANT POINTS THAT YOU SHOULD NOTICE.

**From 1492. PORTUGAL.** The history of the Inquisition in the Iberian Peninsula entered into a new phase with the events which took place in Portugal in 1497. The so-called expulsion of the Jews from that country is in most respects a misnomer. King Manuel I, desiring to secure the extirpation of Judaism without the loss of the industry and resources of his Jewish subjects, had them all seized and baptized by force, without allowing them the alternative of leaving the realm.

Ultimately, however, the king gained the day, offering the pope the administration of the revenues of the enormously wealthy see of Viseu in return for compliance to his wishes. The pope at last surrendered to this magnificent bribe and, on July 16, 1547, by the bull *Meditatio cordis*, the Inquisition was at last fully established in Portugal.

The number of autos-da-fé and of penitents increased year by year. The abuses of the system became so great that the eloquence of the learned Jesuit, Antonio da Vieira, procured from Pope Clement X a bull suspending the operation of the Portuguese inquisitors (Oct. 3, 1674). Since the inquisitors refused to comply, this was followed four years later by an interdict pronounced upon them by Innocent XI (Dec. 24, 1678). Ecclesiastical prejudices were too strong, however, to acquiesce in this state of affairs. By a bull of Aug. 22, 1681 the Portuguese Inquisition was reinstated in all of its former authority with no more than one or two minor reforms and the event was celebrated in a fresh burst of activity. On Jan. 18, 1682, the first auto-da-fé since the interdict was held at Coimbra, but it was surpassed by the one which took place at Lisbon on May 10 of the same year—one of the most notorious in the whole of Portuguese history. The revived power of the Inquisition was further manifested in a new regulation that the children of condemned heretics might be taken away from their parents to be brought up in all the traditions of the Catholic faith (1683). For half a century to come the Inquisition in Portugal continued its bloody career without any great intermission.

**SPAIN.** Meanwhile the activities of the Inquisition in Spain had continued unabated under Diego Deza (1499–1507), the successor of Torquemada as grand inquisitor, himself of Jewish blood. During his period of office, the excesses committed under his auspices—in particular by Diego Rodríguez Lucero, the inquisitor of \*Córdoba—were notorious: accusations were made wholesale on the flimsiest grounds; incredible cruelties were perpetrated; and no accused person had any chance to escape. The culmination was reached when no less than 107 persons were burned alive on an accusation of having listened to the preaching of one Membrequé, a bachelor of divinity.

**Statistics. FOR SPAIN.** It is estimated that in Spain, from the establishment of the Inquisition down to 1808, the number of heretics burned in person was 31,912; those burned in effigy, 17,659; and those reconciled *de vehementi* (see Procedure, below), 291,450—a total of 341,021 in all.

Even these immense figures are apparently exceeded by the usually careful Amador de los Rios, who estimates that up to 1525, when the Moriscos first began to suffer, the number of those burned in person came to 28,540; those burned in effigy to 16,520; and those penanced to 303,847—making a total of 348,907 condemnations for Judaism in less than half a century.

**FOR PORTUGAL.** As far as Portugal and its dependencies are concerned, the figures can be given with a much greater approach to precision. There are extant the records of approximately 40,000 cases tried before the Inquisition in the 16th, 17th, and 18th centuries in Portugal, the archives in this respect being virtually complete. The sentences were carried out at autos-da-fé numbering something like 750 in all. In these, as far as can be ascertained, upward of 30,000 persons were condemned, 1,808 of them being burned at the stake (633 in effigy and 1,175 in person) and 29,590 being penanced. In the two decades from 1701 to 1720, 37 persons were burned in person and 26 in effigy, while 2,126 were penanced. From 1732 to 1742, 66 persons were burned. From 1721 to 1771, 139 persons were burned in person, and 20 in effigy, while 3,488 were penanced.

**The Inquisition in the Spanish Colonies. MEXICO.** Greater still was the importance of the Conversos in the Spanish possessions in America. From 1502 to 1802 the Spanish crown and the pope issued numerous briefs aimed at prohibiting the entry of Jews and Moors to the New World. Anybody who arrived in the colonies had to prove that he was a Christian, with four generations of Christians behind him.



*Tribunal of the Spanish Inquisition in Mexico City applies torture to Francisca de Carabajal to extract a confession, 1590. (From Palacio's El Libro Rojo.)*

REMEMBER WHEN YOU READ "CHRISTIAN" IN REGARDS TO THE INQUISITION, YOU MUST UNDERSTAND IT TO MEAN ROMAN CATHOLICS. REFER TO REVELATION 13:16-18 AND APOLOGETICS 34. THE MARK HAS BEEN USED FOR A LONG TIME.

From 1642 there was a period of relentless activity. A mere child, Gabriel de \*Granada, arrested in that year was made to give evidence against over 80 persons, including the whole of his own family (the record of his trial, published in AJHSP, 7 (1899), is among the most complete inquisitional records available in print in any language).

**Procedure.** In the course of time, the Spanish Inquisition evolved an elaborate procedure of its own. When a tribunal was opened at any place, an edict of grace would be published, inviting those conscious of heresy to come forward and make confession within a "period of grace," generally of 30 or 40 days. After the lapse of this period they could be proceeded against by Inquisition officers. At later stages, an edict of faith would periodically be issued, summoning all persons, under pain of excommunication, to denounce to the authorities all offenses enumerated in it of which he might have cognizance. These invariably comprised all those popularly associated with Judaism: lighting candles on Friday evening, changing the linen on the Sabbath, abstaining from pork and scaleless fishes, observing the Jewish holidays and especially the Day of Atonement and the fast of Esther, laying out the dead according to the Jewish custom, etc. By this means, the whole population became accomplices of the Inquisition in its task of eradicating heresy; and the denunciation of one of the customs mentioned above, performed absentmindedly or by mere force of habit, was frequently sufficient to bring a man to the stake.

**ARREST AND EVIDENCE.** Everything took place under the greatest secrecy, which became one of the main terrors of the Inquisition. Any breach of this was liable to be punished with the utmost severity, like heresy itself. From the moment of arrest, therefore, the utmost segregation obtained. The accused persons were confined in the dungeons of the Inquisition, such as may still be seen in Évora and elsewhere. As was inevitable, there were sometimes terrible abuses, women suffering especially; and it happened more than once that female prisoners were dragged pregnant to the stake.

The rules governing evidence were so devised as to exclude all witnesses who were likely to be of any use to the prisoner, on the ground that their evidence would be untrustworthy. No such scruples, however, prevailed with regard to witnesses for the prosecution, who were frequently inspired merely by venom. Moreover, the names of the accusers were suppressed, though originally this was supposed to be permissible only in the case of "powerful persons" who might intimidate the witnesses. The accusers and accused were thus never confronted. The evidence admitted was flimsy in the extreme: mere regard for personal cleanliness might be sufficient to convict a man of Judaism or Islam, and so cost him his life. Once the accusation was made, the subsequent procedure was based upon a desire to make the accused person confess his crime and thus be admitted to penitence. If this was not forthcoming spontaneously, in accordance with the spirit of the age, torture might be applied; though as a matter of fact in this particular instance the Spanish Inquisition, notorious though its cruelties were, compared favorably with the Roman, where torture might be continued even after

confession in order to extort the names of accomplices. Death under torture was by no means uncommon. In most cases, however, the physician who was present enforced sufficient moderation to avoid this conclusion. Generally, the torture was abundantly sufficient to elicit a confession, if one had been withheld up to that point. It was imposed in most cases only to procure the confession of what the inquisitors already knew or suspected. The cases in which a condemnation was avoided were therefore few in the extreme. Thus, in the Toledo tribunal between the years 1484 to 1531 they totaled on an average less than two yearly. In the Portuguese Inquisition, the number of condemnations came to well over three-quarters of the total number of cases tried.

**PUNISHMENTS.** Often, in the case of any convicted person who professed repentance, "reconciliation" followed and the defendant was restored to the bosom of the Church.

One of the strongest weapons of the Inquisition was the power it had of confiscating the property of those convicted of heresy. At the beginning, the proceeds were devoted to the use of the crown, but they gradually devolved more and more upon the Inquisition itself.

**THE DEATH PENALTY.** The final sanction of the Inquisition was that of death. As an ecclesiastical body, however, it was not permitted itself to be a party to this. It therefore "relaxed" the convicted person to the secular arm, with a formal recommendation for mercy, adding that if it were found necessary to proceed to the extreme penalty, it should be done "without effusion of blood"—that is, by burning. This was an old legal fiction of the Catholic Church dating back to the 11th or 12th century; and the mode of punishment was justified by a text in John 15:6: "If a man abide not in me, he is cast forth as a branch, and is withered: and men gather them, and cast them into the fire, and they are burned."

Generally speaking, the extreme penalty was reserved for those who refused the opportunity for repentance: either the contumacious, who gloried in their crime and died true martyrs; or the "relapsed," who had been reconciled on some previous occasion and whose backsliding proved their insincerity; or the diminutos, whose confession was incomplete and who shielded their accomplices; or the negativos, who refused to confess to the charges made against them in the hope of escaping conviction.

However, by no means all of those executed capitally were burned alive. A profession of repentance, even after condemnation, was almost always effective in securing preliminary garroting, only the corpse then being burned at the stake.

The effigies of fugitives, with the bones of those who had escaped justice by death (sometimes in prison or under torture) would similarly be committed to the flames. Those burned in effigy on certain occasions sometimes totaled something like half as many as those burned in person. This was far from an empty formality, as the condemnation secured the confiscation of their property, while reconciliation was in such cases obviously outside the bounds of possibility.

THE 7TH WORLD POWER TOOK SUCH DELIGHT IN ITS ANTISEMITISM, THAT IT MADE THE BURNING ALIVE OF JEWS INTO A GREAT CELEBRATION. COULD YOU SIT AND WATCH "PEOPLE" BEING BURNED ALIVE, OR PERHAPS FIRST BEING STRANGLD AND THEN THEIR BODIES BURNED? THE ADVERSARY MUST HAVE BEEN VERY SATISFIED WITH HIS MINISTERS OPERATING THE 7TH WORLD POWER. THERE IS A PICTURE OF A PARADE OF THE PARTICIPANTS AS THEY ENTERED THE "CHURCH". (PAGE 46) CAN YOU NOT SEE THAT THE 7TH WORLD EMPIRE, THE ROMAN ECUMENICAL ASSEMBLY, IS UNDER "SATAN'S" AUTHORITY?

RECALL A STATEMENT MADE BY JESUS IN A PARABLE TO JEWS, BEFORE THE CROSS, IN MATTHEW 25:40. JESUS IS THE KING IN THIS PARABLE. "AMEN I-AM-SAYING TO YOU, UPON AS-MUCH-AS YOU-DID TO-ONE OF-THESE MY BROTHERS, namely-THE LEAST, YOU-DID TO-ME."

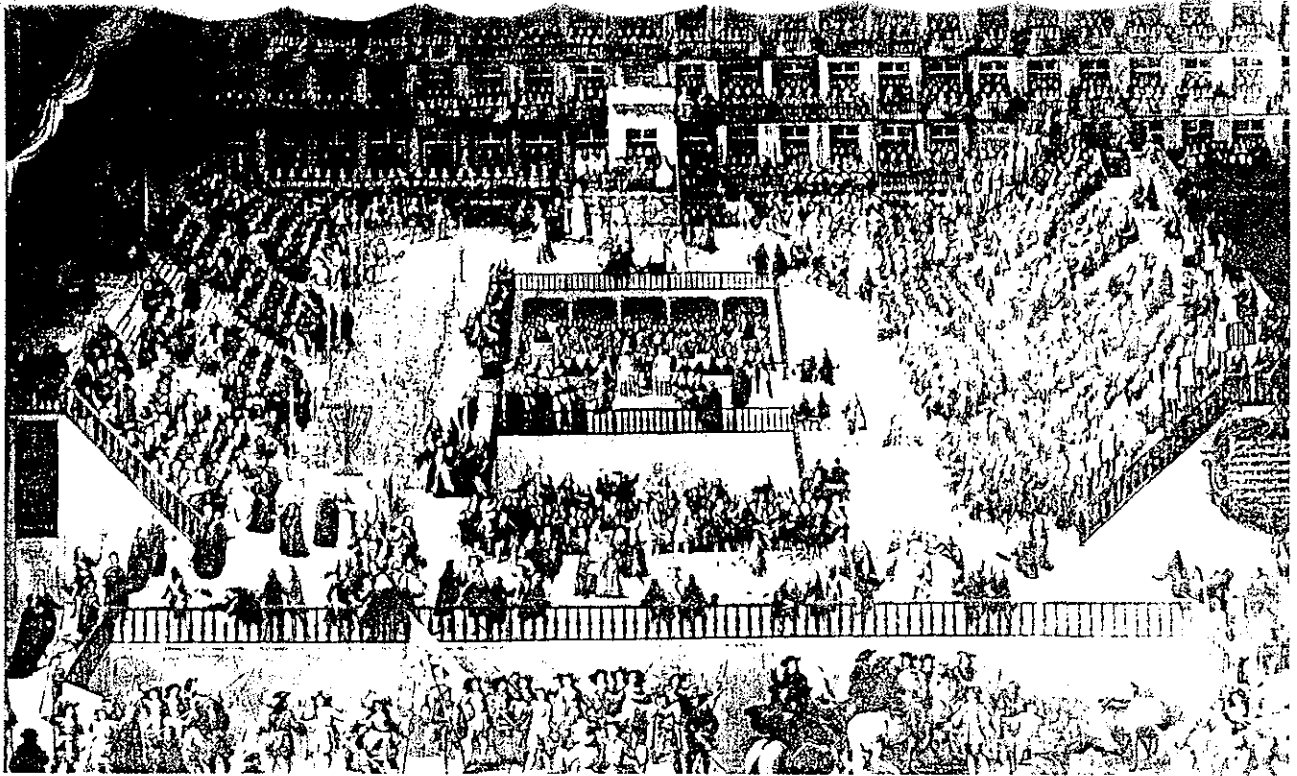

Figure 7. "Auto da Fé" a painting by F. Rizi of the ceremonial sentencing of heretics in Madrid on June 30, 1680, in honor of Charles II and his bride, 1683. Madrid, Prado Museum.

**THE AUTOS-DA-FÉ.** The sentences of the Inquisition were announced at the so-called Act of Faith: auto-de-fé as it was termed in Spain and auto-da-fé in Portugal. For lighter offenses, the ceremonial might be private (auto particular or autillo), in which case it would be held in a church; but this was rarely resorted to for so grave a crime as Judaizing, particularly as it was considered wrong to pronounce a sentence of death in the sacred precincts. In most cases, the ceremony was public (auto publico general). This ultimately became the subject of elaborate organization. The ceremony would take place on some feast day in the principal square of the city. Ample notice was given so as to attract as large a group of spectators as possible, spiritual benefits being promised to all who were present. Two stagings were erected at vast expense—one for those convicted and their spiritual attendants, and the other for the inquisitors and the rest of the authorities, while a temporary altar, draped in black, was set up in the middle.

The proceedings would be opened by a procession in which all the clergy of the city took part. Behind them followed those condemned to appear. All those abjuring *de vehementi* had to carry lighted tapers in their hands and to wear the *sanbenito* or *saco bendito* (the *abito* as it was called in the official sentence). This, which was an innovation of the Spanish Inquisition, consisted of a long yellow robe, transversed by a black cross (in the case of those convicted of formal heresy alone, only one of the arms was necessary). In case the heretic had escaped the stake by confession, flames were painted on the garment, which was sometimes of black. Those condemned to be burned bore in addition pictures of demons thrusting the heretical into hell, while they wore tall miters similarly adorned for additional prominence (the use of these, which were worn in different forms also by bigamists and perjurers, was forbidden by the Roman Inquisition in 1596). In certain cases, as an additional punishment, the *sanbenito* had to be worn in public even after the release of the prisoner, exposing him to universal scorn and derision.

An unrepentant Marrano in sanbenito attire weeps as he walks to his death in an auto-da-fé. (Engraving by Bernard Picart, early 18th century.)



After it was removed, it was generally hung up in the parish church of the delinquent accompanied by a fitting inscriptions, thus marking out the wearer and his family for lasting humiliation. These memorials of shame were destroyed only with the abolition of the Inquisition in the early years of the 19th century.

When the procession had arrived in the square where the auto-da-fé was to be celebrated, amid general scorn the penitents would take their place on the scaffolding reserved for them. A sermon would then be preached by some distinguished cleric, directed especially against the penitents, upon whose heads a torrent of the most unsparing insults would be poured. They would then appear one by one before the pulpit to hear their sentences, which would hitherto have been kept a profound secret. This took some time, the proceedings often being protracted into night and sometimes being spread over two or even three days. The sentences of those "relaxed" to the secular arm were left to the last. They were then formally condemned to death by the civil magistrate and escorted to the quemadero (or brasero), the place of burning, by a detachment of soldiers, whose presence was sometimes necessary to save them from a violent but more humane death at the hands of the infuriated mob.

To light the brand with which the pyre was kindled was considered a religious duty and honor of the highest degree and frequently fell to the lot of visiting royalty. The ashes of the victims were supposed to be scattered to the winds. A repentant heretic would sometimes be strangled before being burned.

During the course of the 16th and 17th centuries, the auto-da-fé came to be regarded as a great public spectacle in the Peninsula and its dependencies, vying in popular appeal with bullfights. Especially splendid celebrations would sometimes be arranged in honor of royalty: thus on Feb. 24/5, 1560, an auto-da-fé was held at Toledo to celebrate the visit of Philip II and his bride, Isabella of Valois; the tribunal of Madrid was inaugurated on July 4, 1632 by an auto-da-fé in celebration of the safe delivery of the queen; but the climax was reached on June 30, 1680 on the Plaza Mayor of the same city, in the presence of Charles II and his bride, Marie Louise d'Orléans, in honor of their marriage. At this, which began at six o'clock in the morning and lasted 14 hours, no less than 51 persons were burned either in person or in effigy, the king himself setting light to the brand which kindled the quemadero. This, as a great court spectacle, formed the subject of a painting by Rizi. It was the last great solemnity of its kind, as Philip V, the first of the Bourbon line, refused (in 1701) to grace with his presence one arranged in honor of his accession, and the usage was henceforth abandoned.

Accounts of the auto-da-fé, giving full details of the names of the victims and the nature of their punishment, with particulars of who was burned alive, who after garroting, or who in effigy, were subsequently printed and hawked about the streets: they form one of the main sources of information for the proceedings. Similarly, the sermons preached at the auto-da-fé were often subsequently published: in Portuguese alone, about 75 are extant in print. They speak of the penitents often as Jews, and in terms of the most outrageous vituperation. Most noteworthy is the sermon delivered on Sept. 6, 1705 at the great auto-da-fé held at Lisbon by the archbishop of Cranganore which was notable for the violence of its language: it was answered by David \*Nieto, haham in London, in a crushing pamphlet which is a masterpiece of polemic and was not without influence in weakening the prestige and destroying the influence of the Inquisition in Portugal. On the other hand, counterparts of these pamphlets were sometimes issued at Amsterdam and elsewhere, where the local rabbis and poets would mourn the death of their martyrs in sermons and elegies. A noteworthy example is the volume of collected pieces published on the occasion of the martyrdom of Abraham Nuñez \*Bernal at Córdoba in 1655. In the prayer books printed for the use of the Converso communities abroad at this period there is included a special \*Ashkavah beginning "God of Vengeance" to be recited in the synagogue in memory of "those burned for the Sanctification of the Name."

MY PRIMARY CONCERN IN THIS DISCOURSE IS TO BRING TO PROMINENCE THE RIVER OF ANTISEMITISM CAST OUT OF THE MOUTH OF THE DRAGON. THE INQUISITION WAS FOLLOWED BY THE HOLOCAUST. FIRST, LET ME SHOW YOU THE QUALITY OF SOME OF THE POPES DURING THE 600 YEARS OF THE INQUISITION. APOLOGETICS 33 AND 34 LIST ALL OF THE POPES.

## HALLEY'S BIBLE HANDBOOK

Honorius III (1216–1227). Gregory IX (1227–1241). Innocent IV (1241–1254), gave Papal Sanction to the use of Torture in extracting confessions from suspected heretics. Under these three Popes, Emperor Frederick II of Germany led his Empire in its last great struggle with Papacy. After repeated wars, the Papacy emerged supreme.

Boniface VIII (1294–1303), in his famous bull, "Unam Sanctam," said, "We declare, affirm, define, and pronounce that it is altogether necessary for Salvation that every creature be subject to the Roman Pontiff." However, he himself was so Corrupt that Dante, who visited Rome during his pontificate, called the Vatican a "Sewer of Corruption," and assigned him, along with Nicolas III and Clement V, to the lowest parts of hell.

70 years (1305–1377), in which Papal Palace was at Avignon. Clement V (1305–1314). John XXII (1316–1334). Richest man in Europe. Benedict XII (1334–1342). Clement VI (1342–1352). Innocent VI (1352–1362). Urban V (1362–1370). Gregory XI (1370–1378).

The Avarice of the Avignon Popes knew no bounds. Burdensome taxes were imposed. Every Church Office was sold for money, and many new offices were created to be sold, to fill the coffers of Popes and support the Luxurious and Immoral Court. Petrarch accused the Papal Household of Rape, Adultery, and all manner of Fornication. In many parishes men insisted on priests keeping concubines as a protection for their own families. The "Captivity" was a blow to Papal Prestige.

John XXIII (1410–1415), called by some the most depraved criminal who ever sat on the Papal Throne; guilty of almost every crime; as cardinal in Bologna, 200 maidens, nuns and married women fell victims to his amours; as Pope he violated virgins and nuns; lived in adultery with his brother's wife; was guilty of sodomy and other nameless vices; bought the Papal Office; sold Cardinalates to children of wealthy families; and openly denied the future life.

Sixtus IV (1471–1484). Sanctioned the Spanish Inquisition. Decreed that money would deliver souls from Purgatory.

Used the Papacy to enrich himself and his relatives. Made eight of his nephews Cardinals, while as yet some of them were mere boys. In luxurious and lavish entertainment he rivaled the Caesars. In wealth and pomp he and his relatives surpassed the old Roman Families.

Innocent VIII (1484–1492). Had 16 children by various married women. Multiplied Church Offices, and sold them for vast sums of money. Decreed the extermination of the Waldenses, and sent an army against them. Appointed the brutal Thomas of Torquemada Inquisitor General of Spain, and ordered all rulers to deliver up Heretics to him. Permitted bull fights on St. Peter's Square. Was Background for Savonarola's cry against Papal Corruption.

Alexander VI (1492–1503), called the most corrupt of the Renaissance Popes, licentious, avaricious, depraved; bought the Papacy; made many new cardinals, for money; had a number of illegitimate children, whom he openly acknowledged and appointed to high church office while they were yet children, who, with their father, murdered cardinals and others who stood in their way. Had for a mistress a sister of a Cardinal, who became next Pope, Pius III (1503).



## HALLEY'S BIBLE HANDBOOK

Julius II (1503-1513), as richest of the Cardinals, with vast income from numerous bishoprics and church estates, bought the Papacy. As a Cardinal he had made sport of Celibacy. Involved in endless quarrels over the possession of cities and principalities, he maintained and personally led vast armies. Called the Warrior Pope. Issued Indulgences for money.

Adrian VI (1522-1523). Clement VII (1523-1534). Paul III (1534-1549). Had many illegitimate children. He was a determined enemy of the Protestants; offered Charles V an army to exterminate them.

Julius III (1550-5): Marcellus II (1555). Paul IV (1555-9). Pius IV (1559-65). Pius V (1566-72). Gregory XIII (1572-85), celebrated, in solemn mass, with Thanksgiving and Joy, the news of St. Bartholomew's Massacre (see page 789). Sixtus V (1585-90). Urban VII (1590). Gregory XIV (1590-1). Innocent IX (1591).

Clement VIII (1592-1605). Leo XI (1605). Paul V (1605-21). Gregory XV (1621-3). Urban VIII (1623-44), with aid of Jesuits, blotted out Protestants in Bohemia. Innocent X (1644-55). Alexander (1655-67). Clement IX (1667-9). Clement X (1670-6). Innocent XI (1676-89). Alexander VIII (1689-91). Innocent XII (1691-1700). Clement XI (1700-21), declared that Kings Reign Only with His Sanction; issued a Bull against Bible Reading. Innocent XIII (1721-4). Benedict XIII (1724-30). Clement XII (1730-40). Benedict XIV (1740-58). Clement XIII, (1758-69). Clement XIV (1769-74), suppressed the Society of Jesuits in Spain, France and Portugal. Pius VI (1775-99). Pius VII (1800-20), issued a Bull against Bible Societies. Restored the Jesuits: one "infallible" Pope restoring for all time what another "Infallible" Pope just before him had suppressed.

Leo XII (1821-9), condemned All Religious Freedom, Tolerance, Bible Societies and Bible Translations; and declared that "Everyone separated from the Roman Catholic Church, however unblameable in other respects, has No Part in Eternal Life."

Pius VIII (1829-30), Denounced Liberty of Conscience, Bible Societies and Freemasonry. Gregory XVI (1831-46), an ardent advocate of Papal Infallibility. Condemned Bible Societies.

Pius IX (1846-78), lost the Papal States; decreed PAPAL INFALLIBILITY; proclaimed the Right to Suppress Heresy by Force; Condemned Separation of Church and State; commanded Catholics to Obey the Head of the Church rather than Civil Rulers; Denounced Liberty of Conscience, Liberty of Worship, Freedom of Speech and Freedom of the Press; decreed the Immaculate Conception and Deity of Mary; Condemned Bible Societies; declared that Protestantism is "No Form of the Christian Religion"; and that "Every dogma of the Roman Catholic Church has been dictated by Christ through His Viceregens on earth."

I HAVE GIVEN A PARTIAL SUMMARY OF THE POPES THAT RULED FROM 1216A.D.-1878A.D. MILLIONS OF PEOPLE HAVE SUFFERED AT THE HANDS OF THE 7TH WORLD EMPIRE, AND YET THE ROMAN UNIVERSAL ASSEMBLY IS STILL THOUGHT OF AS "THE CHURCH". MODERN POPES HAVE SOMETIMES PUT ON A DIFFERENT FRONT, BUT PLEASE TELL ME WHEN DID THE ADVERSARY CHANGE FROM A DRAGON AND SERPENT TO A "CHRISTIAN CHURCH"? WHY DOES THE POPE STILL HATE GOD'S SPECIAL PEOPLE? WHY HAVE THE POPES NOT RECOGNIZED THE STATE OF ISRAEL? THE ANSWER IS SIMPLE, "THE DRAGON WAS-MADE-WROTH OVER THE WOMAN"---ISRAEL.

NOTE THE ASTERISK ON PAGE 51, AND THE WORD "CORRUPTION". HERE IS ANOTHER EXAMPLE OF THE SERPENT'S WORK AMONG TRANSLATORS. THIS IS EXAMPLE NUMBER 14. REFER TO THE TEACHING DICTIONARY, PAGE 364. THE KING JAMES TRANSLATES THE GREEK WORD "PHTHEIRO" BY THE ENGLISH WORD "TO-CORRUPT" 6X. HOWEVER, IN 1 CORINTHIANS 3:17, WHERE THIS GREEK WORD OCCURS TWICE, THE KING JAMES USES TWO DIFFERENT ENGLISH WORDS. WHY? THE KING JAMES USES "DEFILE" AND "DESTROY". ALL EIGHT TRANSLATORS USED IN OUR EXAMPLE FOLLOW THE KING JAMES; THUS THE WORK OF GOD IN THE 7TH WORLD EMPIRE IS HIDDEN.

### King James Version

### I CORINTHIANS 3:17

### Phillips Modern English

- \* 16 Know ye not that ye are the temple of God, and *that* the Spirit of God dwelleth in you? 17 If any man defile the temple of God, him shall God destroy; for the temple of God is holy, which temple ye are.

- Don't you realise that you yourselves are the temple of God, and that God's Spirit lives in you? God will destroy anyone who defiles his temple, for his temple is holy—and that is exactly what you are!

### Living Bible



### Revised Standard Version

- 16 Don't you realize that all of you together are the house of God, and that the Spirit of God lives among you in his house? 17 If anyone defiles and spoils God's home, God will destroy him. For God's home is holy and clean, and you are that home.

- \* 16 Do you not know that you are God's temple and that God's Spirit dwells in you? 17 If any one destroys God's temple, God will destroy him. For God's temple is holy, and that temple you are.

### Today's English Version

### Jerusalem Bible

- 16 Surely you know that you are God's temple, and that God's Spirit lives in you! 17 So if anyone destroys God's temple, God will destroy him. For God's temple is holy, and you yourselves are his temple.

- 16 Didn't you realize that you were God's temple and that the Spirit of God was living among you? 17 If anybody should destroy the temple of God, God will destroy him, because the temple of God is sacred; and you are that temple.

### New International Version

### New English Bible

- 16 Don't you know that you yourselves are God's temple and that God's Spirit lives in you? 17 If anyone destroys God's temple, God will destroy him; for God's temple is sacred, and you are that temple.

- \* Surely you know that you are God's temple, where the Spirit of God dwells. Anyone who destroys God's temple will himself be destroyed by God, because the temple of God is holy; and that temple you are.

\* TWENTY ONE TIMES THE WORD "TEMPLE" IS INCORRECTLY USED FOR THE WORD "NAOS", WHICH MEANS "SANCTUARY". THE WORDS HOUSE AND HOME AS IN THE LIVING BIBLE HAVE NO SUPPORT IN THE GREEK TEXT.

● THE WORDS "DEFILE" AND "DESTROY" SIMPLY COPY THE ERROR OF THE KING JAMES. THE SERPENT HAS HIDDEN GOD'S TRUTH VERY WELL. NOW COMPARE TO THE CONSISTENT TRANSLATION; WHICH ESSENTIALLY USES ONE ENGLISH WORD FOR ONE GREEK WORD. THE ROMAN ECUMENICAL ASSEMBLY HAS BEEN "CORRUPTING" BELIEVERS. GOD HAS CERTAINLY EXPOSED THIS FACT. YOU ASK, HOW? BY "CORRUPTING" THE POPES, CARDINALS, BISHOPS AND OTHER LEADERS. THE CONSISTENT TRANSLATION MAKES THIS PLAIN. COMPARE EXAMPLE 14 TO EXAMPLE 13 ON PAGE 40. THESE EXAMPLES HAVE A LOT IN COMMON.

### I CORINTHIANS 3 CT

- 16 Are-YOU not knowing-absolutely that YOU-are *the* sanctuary-of-God and the Spirit-of-the God is-dwelling in YOU?
- \* 17 If someone is-corrupting the sanctuary-of-the God, the God will-corrupt this one; for the sanctuary-of-the God is holy, which-ones YOU yourselves are. \*

BEFORE JESUS TOLD THE JEWS ABOUT THE HATRED AND PERSECUTION THAT THEY WOULD RECEIVE DURING THEIR LONG DISPERSION AMONG THE GENTILES; JESUS GAVE THEM WORDS OF HOPE. THE APOSTLE PAUL, BY THE HOLY SPIRIT, EXPLAINS TO GENTILES THE RELATIONSHIP BETWEEN JEWS AND GENTILES WHO WOULD BE UNITED THROUGH JESUS.

READ CAREFULLY THE WORDS SPOKEN BY JESUS TO THE JEWS, NOT GENTILES, IN MATTHEW 5:10-12. THEN GO BACK AND STUDY AGAIN EXAMPLE 10 ON PAGE 22. PAUL'S EXPLANATION TO YOU, AS A GENTILE, IS VERY IMPORTANT FOR YOU TO KEEP IN MIND. GOD HAS NOT, AND WILL NOT, "PUSH AWAY FOM HIMSELF HIS PEOPLE", THAT IS, THE JEWS.

#### MATTHEW 5 CT

10 Happy the *ones* having-been-and-still-persecuted on-account-of justice; because of-them is the kingdom of-the heavens.

11 Happy are-YOU at-the-time-that they-might-reproach YOU and they-might-persecute, and *ones*-lying-for-themselves might-say every evil saying against YOU, on-account-of me.

12 YOU-be-rejoicing and YOU-be-exulting, because YOUR reward *is* much in the heavens; for thus they-persecuted the prophets *namely*-the *ones* before YOU.

#### ROMANS 11 CT

1 I-am-saying therefore, Has the God pushed-away-from-himself his people? No! May-it-not-come-to-pass; for I myself also am *an* Israelite, out-of seed of-Abraham, of-the-tribe of-Benjamin.

2 The God *has* not pushed-away-from-himself his people whom he-came-to-know-before.

7 What then? What Israel is-seeking-after, this it-attained not, but the choice attained; but the others were-petrified,  
8 Even-as it-has-been-and-is-still-written: The God gave to-them a spirit of-compunction, eyes not to-be-looking and ears not to-be-hearing, till of-the today day.

11 I-am-saying therefore, Have they-slipped in-order-that they-might-fall? No! May-it not come-to-pass; BUT by-their offence the salvation to-the Gentiles, with-reference-to, to-provoke them to-jealousy.

12 But if their offence *is* riches of-a-world and their inferiority *is* riches of-nations, in-how-much more their fullness.

13 But I-am-saying to-YOU to-the Gentiles; On as-much-as on-the-one-hand therefore I myself-am *an* apostle of-nations, I-am-glorifying my ministry,

14 If-by-any-means I-shall-provoke-to-jealousy of-my flesh and I-might-save some out-of them.

15 For if the casting-off of-them *is* reconciliation of-a-world, what the taking-near if not life out-of dead *ones*?

16 But if the firstfruit is holy, also the lump; and if the root is holy, also the branches.

17 But if some of the branches were-broken-out, but you being a wild-olive-tree yourself-were-grafted-in among them and you-became a fellow-partner-of-the root and of-the fatness-of-the olive-tree,

18 You-be not boasting-against the branches; but if you-are-boasting-against *them*, you yourself-are not bearing the root BUT the root you.

19 You-will-say therefore: Branches were-broken-out in-order-that I myself-might-be-grafted-in.

20 Rightly: they-were-broken-out by-the distrust, but you yourself-have-stood-and-still-are-standing by-the trust. You-be not having-an-opinion-of high-things, BUT you-be-fearing-for-yourself;

21 For if the God spared not of-the branches according-to nature, neither will-he-spare of-you.

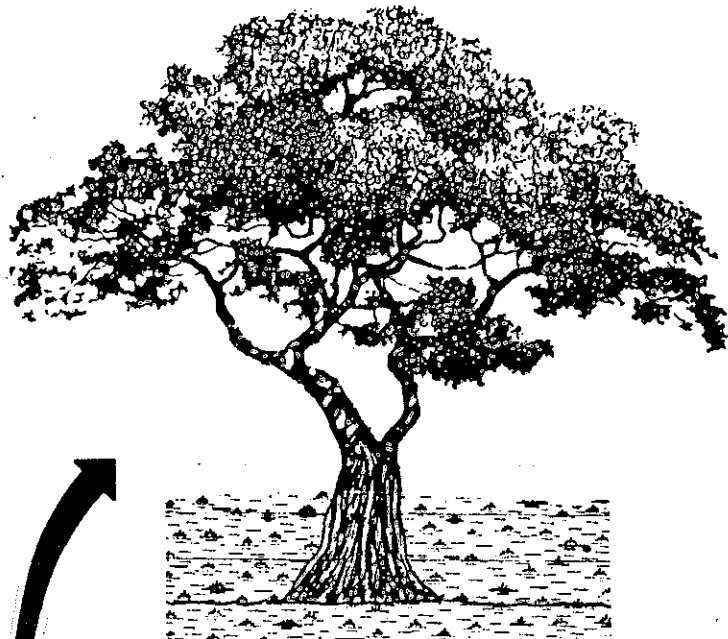

22 See therefore graciousness and severity of-God: on-the-one-hand on the *ones* having-fallen severity, on-the-other-hand on you graciousness of God, if you-might-continue in-the graciousness, since you yourself also will-be-chopped-away,

23 But also-those, if they-might not continue in-the distrust, they-will-be-grafted-in; for the God is powerful to-graft them in again.

24 For if you yourself-were-chopped-away out-of the wild-olive-tree according-to nature and from nature you-were-grafted-in into a cultivated-olive, by-how-much rather these, the *ones* according-to nature, will-be-grafted-in to-their-own olive-tree.

25 For I-am not willing for YOU to-be-being-ignorant brothers, of this mystery, in-order that YOU-might not be prudent in yourselves, that petrification has-come-to-pass-and-still-is from part to-the Israeli, until of-which time the fulness of-the Gentiles might-come-in,

26 And thus all Israel will-be-saved, according-as it-has-been-and-still-is-written: The *one* delivering will-be-present out-of Sion, he-will-turn-back impiety from Jacob.

27 And this is the covenant from me to-them, at-the-time-that I-might-remove-for-myself their sins.

THE HATRED AND PERSECUTION OF THE JEWS DID NOT END WITH THE INQUISITION. THE TREATMENT OF THE JEWS IN THE HOLOCAUST WAS FAR WORSE. EUROPE HAD BEEN TAUGHT TO HATE THE JEWS BY THE "CHURCH". THE ROMAN CATHOLIC CHURCH HAD PREPARED THE WAY FOR HITLER. EVEN THE "REFORMER" MARTIN LUTHER HATED THE JEWS. THIS CARTOON IN 1938 CLEARLY SHOWS THE CONNECTION BETWEEN THE INQUISITION AND THE HOLOCAUST.

ON PAGE 28A I SHOWED THE "RIVER OF ANTISEMITISM" FROM SCRIPTURE. THE 4 VOLUME SET OF THE ENCYCLOPEDIA OF THE HOLOCAUST, 1990 USES THE VERY SAME BIBLICAL WORD "RIVER".

JUDAICA VOL.8 PAGE 850



Figure 15. The Grand Inquisitor: "Congratulations, dear colleague! You've really far outdone us!!" A cartoon from *Deutsche Zeitung Tageblatt*, a German-language daily published in Moscow, November 28, 1938. Courtesy Z. Efron, En-Harod.

#### ENCYCLOPEDIA OF THE HOLOCAUST P.295

There is also an emerging realization that the river of modern antisemitism has been fed by ancient streams of theological and cultural Jew-hatred.

The river reached flood proportions in the German Third Reich, when streams of ethnic (*völkisch*) racism and pseudoscientific racial anthropology combined with motives of blatant economic pillage and political expediency. The river of anti-Jewish violence then overflowed the familiar channels of nonviolent discrimination and occasional mob violence that had long carried the ill will of Christendom toward Jews. The force of the flood was not accidental, however: its power was purposefully harnessed to rational engines of destruction intended to wipe Jewry from the face of the earth.

Although the number of books and articles on the subject has greatly increased since the 1960s, still comparatively rare is evidence that the churches' officials and courts have come to terms with Christianity's own contribution to the attempted destruction of the Jews. The greatest progress has been made in local centers.

Even resolutions against "antisemitism" and "racism" are usually cast in such form as to make it clear that the unpleasant acts were something that was done by other people. Still protected from radical surgery, still unthreatened by any deep and insightful repentance, both theological and cultural antisemitism are alive in most of the Christian world—including circles that readily condemn what they call "racial prejudice," "anti-Judaism," or "anti-Semitism" (that is, political antisemitism).

Nevertheless, in contemporary theological writing the focus is on the frontier between the Christian churches and the Jewish people. The acid tests as to whether hierarchies and churches have made the pilgrimage of faith in the shadow of Auschwitz are three:

- (1) the attitude toward teaching the Holocaust and the lessons of the Holocaust; (2) the attitude toward a restored Israel; and (3) the attitude toward organized missions to the Jews (*Judenmissionen*). The red thread that ties these three issues together is the response to the question, "How do you stand on the question of the survival of the Jewish people?"

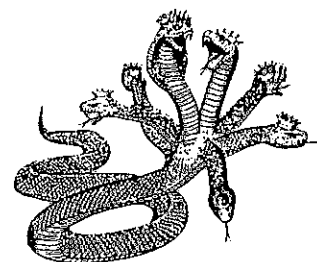

THE SOURCE OF THE RIVER.

EVEN THOUGH MARTIN LUTHER LIVED ABOUT 400 YEARS EARLIER; HE HAD A GREAT EFFECT UPON THE HOLOCAUST. THIS IS AN ARTICLE FROM JUDAICA SHOWING LUTHER'S CHANGE OF ATTITUDE; HIS "VOLTE-FACE", ●\* THAT IS, HIS ABOUT FACE. I BELIEVE IT ILLUSTRATES HOW THE SERPENT CAN INFLUENCE A PERSON'S THINKING. SEE LUTHER'S OWN REMARKS IN APOLOGETICS 26, PAGE 8.

°LUTHER, MARTIN (1483-1546), German religious reformer. During the first period of his activity (approximately 1513-23), Luther often condemned the persecution of the Jews and recommended a more tolerant policy toward them, based on the spirit of true Christian brotherhood. Commenting on Psalm 22 (around 1519), he roundly condemned the "Passion preachers [who] do nothing else but exaggerate the Jews' misdeeds against Christ and thus embitter the hearts of the faithful against them." Speaking of the controversy between Johann \*Reuchlin and Johann \*Pfefferkorn, he strongly disapproved of the confiscation of the Talmud and rabbinic literature. Even in later times he referred to Reuchlin as his predecessor and teacher. Although declaring that it was impossible to expect the conversion of the whole Jewish people, he nevertheless nurtured the belief that, after listening to his teachings, many Jews would acknowledge the truth and accept Christianity.

Luther directly considered the Jewish question first in his pamphlet *Dass Jesus Christus ein geborener Jude sei* ("That Christ Was Born A Jew," 1523). Arguing that the Jews, who were from the same stock as the founder of Christianity, had been right in refusing to accept the "papal paganism" presented to them as Christianity, he added, "If I had been a Jew and had seen such fools and blockheads teach the Christian faith, I should rather have turned into a pig than become a Christian." Partly because of his polemics against the use of images in churches, he himself was branded a "half-Jew" (semi-Judaeus) by the church authorities. Perhaps encouraged by his conversion of one of the two Jews who had reportedly visited him at the Diet of Worms (1521), Luther had high hopes for the success of his mission among the Jews. Early missionary attempts had failed "not so much [because of] the Jews' obstinacy and wickedness, as rather [through] the absurd and asinine ignorance and the wicked and shameless life of the popes, priests, monks, and scholars." Pending their seeing the light, the Jews should be treated more considerately and given greater opportunities to gain a livelihood.

At first, Luther's disruptive impact on Roman Catholicism (which the Jews equated with the detested kingdom of \*Edom) was welcomed by Jews as a break in the monolithic power of the Church. Others hoped that the turmoil arising in the Christian world through the spread of Lutheranism would lead to toleration of all forms of worship. Moreover they expressed the view that a partial reform of the Church was welcome since it led the Church away from its former evil.

However, although appreciating Luther's apparent kindness toward them, the Jews resisted his message. Whether through irritation at their refusal to accept his truth or for some other reason, Luther grew increasingly hostile toward the Jews. In 1526 he complained of the Jews' stubbornness in clinging to their traditional interpretation of Scripture. His repeated attacks on usury began to assume an anti-Jewish bias and his successive *Table Talks* of the 1530s contain frequent complaints about "the stiffnecked Jews, ironhearted and stubborn as the devil."

The increasing vehemence of his attacks is apparent in his "Letter Against the Sabbatarians," in which he harshly condemns that Protestant sect for adopting Jewish customs. Openly anti-Jewish and couched in Luther's characteristic style of extreme vituperation are two pamphlets written in 1542 and 1543, "On the Jews and Their Lies" and "On the Shem Hamephoras" ("The Ineffable Name"). Repeating the accusations and invective of medieval anti-Jewish polemics and making use of the works of the apostates Antonius \*Margaritha and Bernhard Ziegler, he subjects the Jews to a torrent of vile abuse, calling them "venomous and virulent," "thieves and brigands," and "disgusting vermin." Although Luther poured out such violent language on the heads of all his enemies—princes, lawyers, bishops, and especially the pope—in the case of the Jews he also made practical suggestions, ranging from forced labor to outright banishment. As many of the Protestant rulers of the times relied on Luther's political advice, his attitude resulted in the expulsion of the Jews from Saxony in 1543 and the hostile *Judenordnung* of Landgrave Philip of Hesse in the same year. The tenor of his suggestions was equally virulent in his "Admonition against the Jews," a sermon preached in 1546, shortly before his death. \*

In Germany in particular, Luther's volte-face in his attitude toward the Jews caused bitter disappointment in Jewish circles. After his request to answer Luther's calumnies had been turned down by the authorities of Strasbourg in 1543, \*Joseph (Joselman) b. Gershom of Rosheim expressed undisguised hostility to the Reformation, calling Luther "the unclean" (לא טהור, a word play on his name). Among Reformation thinkers, a certain group (notably the Swiss Heinrich Bullinger and the Nuremberg preacher and Hebraist, Andreas \*Osiander) criticized his anti-Jewish stance.

Despite his fight against Judaism, Luther had a deep and abiding love for the Hebrew Bible. Although his Hebrew was weak and his Greek little better, his translation of the Bible into German was one of the most significant in literary history. He accepted the Hebrew language as the only one adequate for the expression of religious truth and sentiment. However, in his translation of and commentaries on the Bible he laid greater stress on intuition and revealed religion than on grammatical or linguistic questions. "I am not a Hebraist with respect to grammar [he said], nor do I wish to be one . . . I rather translate freely . . . Accurate interpretation is a special gift of God."

Inconsistency and violence characterized Luther's utterances in all fields, but perhaps in none with more disastrous consequences than in his statements on the Jews. Due to his vituperative anti-Jewish polemics, the Lutheran Church, unlike that which owed its foundation to John \*Calvin, retained all the superstitious abhorrence of the Jews inherited from the medieval Catholic Church. Indeed Luther's attitude was worse, for he recognized no duty to protect the Jews. Throughout the subsequent centuries Luther's ferocious castigation of the Jews provided fuel for anti-Semites and the vicious force of that legacy was still evident in Nazi propaganda.



ON PAGE 17, I POINTED OUT THAT THERE WERE 2 BIRTHS IN REV.12. REVIEW PAGE 17 AND THEN READ VERY CAREFULLY THE FOLLOWING VERSES.

REVELATION 12 CT

1 And *a* great sign was-seen in the heaven, *a* woman having-been-and-still-cast-around *with* the sun, and the moon underneath her feet and on her head *a* crown of-stars twelve,  
 2 And having in *her* womb, and suffering-birth-pains she-is-crying and being-tormented to-bring-forth.

ISAIAH 66:7, SEPTUAGINT

"BEFORE EITHER THE SUFFERING-BIRTH-PAINS TO-BRING-FORTH, BEFORE TO-COME THE TOIL OF-THE BIRTH-PAINS, SHE-FLED-OUT AND BROUGHT FORTH (A) MALE.

## World War I

MATTHEW 24 CT

6 But YOU-will-be-about to-be-hearing-of wars and reports of-wars; YOU-be-seeing YOU-are not being-alarmed for it-is-essential all-things to-come-to-pass, BUT the finish is not-yet.  
 7 For nation will-be-raised over nation and kingdom over kingdom; and famines and pestilences and earthquakes will-be according-to places.  
 8 But all these-things are beginning of-birth-pains.

MARK 13 CT

7 But at-the-time-that YOU-might-hear wars and reports of-wars, YOU-be not being-alarmed; for it-is-essential to-come-to-pass, BUT not-yet the finish.  
 8 For nation will-be-raised upon nation and kingdom upon kingdom; and earthquakes will-be according-to places, and there-will-be famines and disturbances. These-things are beginnings of-birth-pains.

## ↶ Jesus spoke to Jews ↷

A LAND BORN IN A DAY, P.81 The Balfour Declaration was actually a very simple declaration written by Lord Balfour to Lord Rothschild and approved by the British Cabinet, November 2, 1917. It reads, "His Majesty's Government view with favor the establishment in Palestine of a National Home for the Jewish people, and will use their best endeavors to facilitate the achievement of this object, its being clearly understood that nothing shall be done which may prejudice the civil and religious rights of the existing non-Jewish Communities in Palestine or the rights and political status enjoyed by Jews in any other country."

Dr. Chaim Weizmann said in his autobiography, TRIAL AND ERROR, p.208, "While the cabinet was in session, approving the final text, I was waiting outside, this time within call. Sykes brought the document out to me, with the exclamation: 'Dr. Weizmann, it's a boy!'"

This seems like a strange remark to be made at the approval of such a simple declaration. Yet, on further examination this remark seems quite appropriate, for we read in Isaiah 66:8: "Shall a land be born in one day?" (ASV)

DIASPORA PROPHESED  
 DEUTERONOMY 28 ASV

63 And it shall come to pass, that, as Jehovah rejoiced over you to do you good, and to multiply you, so Jehovah will rejoice over you to cause you to perish, and to destroy you; and ye shall be <sup>e</sup>plucked from off the land whither thou goest in to possess it. 64 And Jehovah will <sup>e</sup>scatter thee among all peoples, from the one end of the earth even unto the other end of the earth; and there thou shalt <sup>e</sup>serve other gods, which thou hast not known, thou nor thy fathers, even wood and stone. 65 And <sup>e</sup>among these nations shalt thou find no ease, and there shall be no rest for the sole of thy foot: but Jehovah will give thee there a trembling heart, and failing of eyes, and pining of soul; 66 and thy life shall hang in doubt before thee; and thou shalt fear night and day, and shalt have no assurance of thy life. 67 In the morning thou shalt say, Would it were even! and at even thou shalt say, Would it were morning! for the fear of thy heart which thou shalt fear, and for the sight of thine eyes which thou shalt see.

SEE ALSO VS.25

Weizmann went on building his structure of support and brought his efforts to a triumphant consummation in the early fall of 1917. Despite the opposition of some British Jews and skepticism in some parts of the British Cabinet, Lloyd George and Balfour eventually approved his request for a statement of sympathy for Zionist aims, and the famous \*Balfour Declaration was issued on Nov. 2, 1917. The Declaration, which was Weizmann's primary achievement, was a turning point in modern Jewish history. The idea of restoring Jewish political nationhood had passed from fantasy into the world of politics. A leading diplomatic historian has described Weizmann's role as "the greatest act of diplomatic statesmanship of the First World War," declaring that "not even . . . Masaryk and Venizelos can compare in stature with Weizmann" (Sir Charles Webster, *The Art and Practice of Diplomacy* (1961), 114). The spectacular nature of his achievement had made him the central figure in the public life of the Jewish people; he was recognized as such by Jews and non-Jews alike. His position in international life even conveyed a premonition of Jewish sovereignty. Heads of state, ministers, and high officials behaved toward him as though he were already president of a sovereign nation equal in status to their own. He and they knew that this was not strictly true; but something in his presence and in their own historic imagination forbade them to break the spell.



CHAIM WEIZMANN

THE ADVERSARY, THE DRAGON, WAS READY TO ATTEMPT TO DESTROY GOD'S CHOSEN PEOPLE, THE JEWS. FOR CENTURIES HE HAD PREPARED THE PEOPLE OF THE 7TH WORLD POWER UNDER AN ILLUSION THAT THE ROMAN CATHOLIC CHURCH WAS CHRISTIAN. THE INQUISITION HARDENED PEOPLE AGAINST THE JEWS. THE ADVERSARY'S MAN TO COMMAND THESE FORCES WAS ADOLF HITLER. EUROPE WAS PREDOMINATELY ROMAN CATHOLIC, AND READY FOR THE TASK. BELOW; A MASSING OF THE MILITARY FORCES.



Figure 1. Nazi Party mass rally in Nuremberg, 1933. Courtesy Schaefer Verlag, Munich.

BELOW ARE JUST A FEW STATEMENTS ABOUT ADOLF HITLER TAKEN FROM JUDAICA, VOL.8, PAGE 782. THERE ARE A FEW STATEMENTS WHICH I THINK GIVE SOME INDICATION THAT HITLER MAY HAVE HAD SOME CONTACT WITH THE ADVERSARY, SIMILAR TO THAT OF MOHAMMED. (DISCOURSE 5, PAGE 42)

\*HITLER, ADOLF (1889-1945), Austrian-born chief of the German National Socialist Party from 1920 and chancellor of the Reich from 1933; Hitler was the man who planned the extermination of the Jews, took the total decision, created the required organization, and followed passionately its implementation; sometimes even in individual cases.

Hitler left Vienna in 1913 to establish himself in Munich. It is unknown to what extent his experiences during World War I influenced his anti-Semitism, but the political situation in the Reich, and in Bavaria in particular, at the end of 1918 and beginning of 1919 further confirmed his hatred of Jews.

In Munich, where Hitler was stationed from the end of 1918, a large number of heads of the ephemeral Soviet Republic of Bavaria were Jews. Hitler declared that he then felt called upon by Providence to devote his life to the struggle against the Jews. In 1919 he joined a small nationalist, anti-Semitic political circle, the Deutsche Arbeiterpartei (German Workers' Party), and in 1920 he set himself up as the *Fuehrer* of the party, which in the meantime had become the National-Sozialistische Deutsche Arbeiterpartei (NSDAP; see \*National Socialism). The struggle against the Jews would become a central and immutable point of the party's ideology.

**Adolf Hitler and the Extermination of European Jewry.** It is not known when Hitler conceived the exact plan for the physical extermination of the Jews. In *Mein Kampf* he wrote that between 12,000 and 15,000 Jews should have been gassed in World War I. On January 30, 1939, he "prophesied" that a new world war would lead to the extermination of the Jewish race in Europe. Thus, the thought of exterminating the Jews was familiar to him.

According to the testimonies of heads of the *Einsatzgruppen* ("special task forces") who were about to enter into action in Russia, the order to execute all the Jews was given to them orally in May 1941. In any case, on July 31, 1941, one

## HOLOCAUST

JUDAICA VOL.8, P.831

**Introduction.** The "Holocaust" (also known as the Catastrophe, the *Sho'ah* שואה, the *Hurban* חורבן) is the most tragic period of Jewish Diaspora history and indeed of modern mankind as a whole. It started in Germany on Jan. 30, 1933, with the accession of the Nazis to power, and ended on May 8, 1945, with the unconditional surrender of Nazi Germany. The 12 years of the Nazi anti-Jewish Aktion (1933-44) constitute an uninterrupted progression toward an ever-increasing radicalization of objectives and barbarization of methods in constantly expanded territories under direct Nazi control or under decisive Nazi influence, to the accompaniment of vicious, sometimes obscene, anti-Jewish propaganda. The consequences of the Holocaust are of decisive significance for the Jewish present and future: those consequences are still evident now and will be experienced for generations to come.

month after the German attack on the USSR, Hermann \*Goering gave to Reinhard Heydrich, head of the Reich Security Main Office, the order to "proceed with all the preparations necessary for organizing the complete solution of the Jewish question in the German sphere of influence in Europe." At the commencement of 1942 the master plan was ready, and on January 20, at the \*Wannsee Conference, Heydrich announced that "the Final Solution of the Jewish Question in Europe should be applied to about 11,000,000 persons."

The extermination of the Jewry of Nazi-occupied or Nazi-controlled territories in Europe was to be carried out by three essential means: mass executions, organized by the Einsatzgruppen, mainly in Russian territory; annihilation by forced labor and disease in the ghettos and concentration and extermination camps; death by gas or by shooting in extermination camps. Hitler personally followed and controlled every phase of extermination.

On June 19, 1943, he repeated his order: "Despite the upset that might result, the evacuation of the Jews must be carried out in the most radical manner."

To his intimate circle, Hitler frequently described the action against the Jews in this period as "one of the greatest revolutions accomplished in the world."

Moreover, in his public speeches, Hitler explicitly referred numerous times to the extermination then in progress: "People always laughed at my prophecies," he declared on November 8, 1942, in reference to his above-mentioned speech of January 30, 1939. "Among those who laughed then," he added, "are innumerable persons who no longer laugh today, and those who are still laughing, will probably soon stop." On February 24, 1943, he was even more explicit: "This struggle," he declared, "will not end with the annihilation of Aryan mankind, but with the extermination of the Jewish people in Europe." Between five to six million Jews were actually exterminated in the framework of Hitler's "Final Solution."

The Jews lived in agony. Tortured by anxiety, insecure in the present, unable to anticipate the future, torn between hope and despair, they were helpless in the face of a tremendous machine always ready to crush them. The psychological effects on those who had to live through this period of total persecution are beyond even superficial description. This survey is an attempt to trace at least the external events, the extraordinary human suffering of a specially selected "race," pursued over the length and breadth of a continent and beyond, condemned to mass murder. Integrated or segregated, educated or ignorant, rich or poor, young or old, every Jew was condemned. East European Jewry, however, was especially singled out, in the belief that by destroying this reservoir of Jewish population and culture, the Nazis would have the ultimate "solution" to the "Jewish question."

THERE IS NO WAY IN WHICH THE FACTS OF THE HOLOCAUST COULD BE PUT INTO A DISCOURSE SUCH AS THIS. THIS PAGE HAS SOME VERY DISCONNECTED STATEMENTS WHICH MAY HELP A LITTLE TO HELP YOU BEGIN TO SEE THE GREAT EFFORT OF THE DRAGON TO DESTROY THE WOMAN; ISRAEL.

### JUDAICA VOL.8, P.832

Two major periods of the Holocaust can be discerned: the prewar period and the period of World War II.

**First Period: From the Nazi Accession to Power to the Beginning of Germany's Military Expansion (1933-39).** THE NAZI ACCESSION TO POWER. On Jan. 30, 1933, the aging president of the German Republic, Paul von Hindenburg, appointed Adolf \*Hitler, leader of the National Socialist (Nazi) German Workers Party (NSDAP), chancellor of the Reich. The program of the party (1920), which was supposed to be "unchangeable" (*"unabänderlich"*), proclaimed the racial principle as the criterion for citizenship, and initiated the institutionalization of racial anti-Semitism as a concrete governmental program. The essential characteristics of this form of anti-Semitism were: its primary importance among the objectives of the "thousand-year Reich"; its world dimensions; its implacable determinism; and its unsurpassed "consistency" and cruelty. Hitler's *Mein Kampf* (1925), the gospel of the movement and of the Nazi state, overflows with hatred and contempt for the Jews. The Nazi Party's attitude toward the Jews is expressed in the coarse slogan: *Deutschland erwache, Juda verrecke* ("Germany wake up, Judah drop dead") and in the words of the S.A. *Sturmlied*: "*Wenn das Judenblut vom Messer spritzt, dann geht's nochmal so gut*" ("And when Jew blood spurts from the knife, things will go twice as well"). What could be expected from the party and its affiliated organizations was demonstrated by numerous acts of violence before the seizure of power (at the hands of the Storm Troopers from 1924 on), as well as by unrestrained propaganda (books, pamphlets, and periodicals, such as *Der \*Sturmer*, published from 1923 on), in which the Jew was presented as a subhuman (*Untermensch*), a parasite, a phenomenon of decay (*Faekulnisserscheinung*), and the main cause of all German misfortunes. "It is our duty," Hitler said in 1920, "to arouse, to whip up, and to incite in our people the instinctive repugnance of the Jews."

**NAZI POLICY.** The aim of the Nazi policy vis-à-vis the Jews during this period was to make Germany and German-controlled areas free of Jews (*judenrein*). By making life unbearable, the Germans forced the Jews to emigrate. Nazi policy was to use "legal" means to "eliminate" (*ausgliedern*) Jews from the German state and society, assigning the racial principle as the dominant guide for the Third Reich. The Jews were eliminated from citizenship, public office, the professions, and the intellectual and artistic life of the country. Public schools were finally closed to Jewish children on Nov. 15, 1938.

Along with this trend, there existed what turned out to be a much more realistic opinion which recognized that there was no hope for Jews in Germany, that expulsion was only a matter of time, and that consequently the solution was emigration. Palestine was the goal for a part of this group, helped by the \*Ha'avarah agreement of 1933. During this period, some 280,000 Jews emigrated, despite the psychological difficulties inherent in such a decision for a community deeply rooted in Germany, and notwithstanding the limitations on emigration.

**Second Period: From the Invasion of Poland to the Defeat of Germany.** With Hitler's invasion of Poland on Sept. 1, 1939, the second period of Nazi anti-Jewish policy and practice started. It was characterized by accelerated lawlessness, pauperization, harassment, and ultimately mass murder of the Jewish population in "Greater Germany" as well as in Nazi-occupied and -influenced areas. The purpose at first was to inflict a slow death on the Jewish community. The entire program was accompanied by vicious propaganda and acts of violence at the cost of thousands of human lives. It culminated during the 1941-44 period in mass extermination of millions by shooting and gassing followed in 1945 by starvation, forced labor, and death marches of the miserable remnants, under the code name "Final Solution."

THE ELEMENTS SPECIFIC TO THE JEWISH SITUATION. The Jewish situation during the war, if compared with the Nazi treatment of Poles, Russians, non-Soviet Communists, and gypsies, was unique in these elements: (1) The destructive will (*Vernichtungswille*) of the Nazis was aimed at the totality of the Jews as Jews, and consequently the victims included women, children, and old people, while it was directed at only a part of the other groups. (2) The "Final Solution" for the Jews was to be achieved immediately, during the war, whereas decisions on the ultimate fate of other peoples were postponed till after victory. (3) Hitler's war against the Jews had priority over his war against all other enemies. (4) In the Jewish case alone there was an absence of inhibitions or conflicting considerations, which played a role in Nazi persecution of non-Jews. Thus, despite the critical manpower situation, particularly in the armament industry, the directive was given (although not entirely obeyed) in December 1941 by the Ministry for the Occupied Eastern Territories that "as a matter of principle (*grundsätzlich*) no consideration should be given to economic interests (*Belange*)." In another critical area, the shortage of rolling stock, Himmler and Eichmann indefatigably insisted that despite urgent requirements by the armed forces, priority should be given to deportations. Indeed, here the insatiable destructive will of the Nazis reached apocalyptic dimensions.

**SECRECY AND DECEPTION.** The fact of deliberate physical destruction of human beings, and particularly of the European Jews, was never mentioned in published Nazi documents.

Various devices were used to insure secrecy (*Geheimnisschutz*). The participants in the operation had to sign a special oath of absolute secrecy (*unbedingte Verschwiegenheit*).

The secrecy was complete and, to a large extent, effective. The very monstrosity of the crime made it unbelievable. In fact, the Nazis speculated that the unimaginability of their *Aktionen* would work in their favor. Commenting on a report of such an *Aktion*, Heinrich Lohse, Nazi commissioner for Ostland, observed: "Just imagine what would happen if such occurrences became known to the enemy and were exploited; but probably such propaganda would have no effect, since those who hear or read it would not be willing to believe it!"

WITH THE BALFOUR DECLARATION OF NOVEMBER 2, 1917, BEFORE THE SUFFERING OF BIRTH PAINS, THE WOMAN BROUGHT FORTH THE CHILD. (SEE PAGE 57) THEN CAME WORLD WAR II AND THE TERRIBLE BIRTH PAINS THAT RESULTED IN THE BIRTH OF THE STATE OF ISRAEL MAY 16, 1948. IT IS OF INTEREST TO NOTE THAT THESE TWO DATES ARE ABOUT 30 YEARS APART. WE READ IN LUKE 3:23: "AND THE JESUS (SAVIOR) HIMSELF WAS ABOUT THIRTY OF-YEARS BEGINNING [HIS MINISTRY]".

THE END OF THE SEASONS OF THE GENTILE'S POSSESSION OF THE CITY OF JERUSALEM WAS JUNE 7, 1967. THIS DATE IS APPROXIMATELY A JUBILEE, 50 YEARS, FROM THE BALFOUR DECLARATION. I DON'T KNOW THAT ALL THIS IS IMPORTANT, BUT TO ME, THESE THINGS ARE OF INTEREST.

## World War II Birth-Pains



Figure 38. Auschwitz. Courtesy Yad Vashem Archives, Jerusalem. Speaking of these crimes in his closing speech to the International Military Tribunal at Nuremberg, Sir Hartley Shawcross said: "In all our countries, when perhaps in the heat of passion or for other motives which impair restraint some individual is killed, the murder becomes a sensation, our compassion is aroused, nor do we rest until the criminal is punished and the rule of law vindicated. Shall we do less when not one, but on the lowest computation twelve million men, women, and children are done to death? Not in battle, not in passion, but in the cold, calculated, deliberate attempt to destroy nations and races, to disintegrate the traditions, the institutions, and the very existence of free and ancient states. Twelve million murders! Two-thirds of the Jews in Europe exterminated, more than six million of them on the killer's own figures. Murder conducted like some mass production industry . . ."

### REVELATION 6 CT

10 And they-cried with-a-great voice saying: Till at-what-time, the Despot *namely*-the holy and authentic, are-you not judging and avenging our blood out-of the *ones* residing on the earth?



Translation of document 2999-PS submitted to the International Military Tribunal, Nuremberg.

I, Hermann Friedrich Graebe, declare under oath:

From September 1941 until January 1944 I was manager and engineer in charge of a branch office in Sdolbunow, Ukraine, of the Solingen building firm of Josef Jung. In this capacity it was my job to visit the building sites of the firm. Under contract to an Army Construction office, the firm had orders to erect grain storage buildings on the former airport of Dubno, Ukraine.

On 5 October 1942, when I visited the building office at Dubno, my foreman Hubert Moennikes of 21 Aussenmuehlenweg, Hamburg-Haarburg, told me that in the vicinity of the site, Jews from Dubno had been shot in three large pits, each about 30 meters long and 3 meters deep. About 1500 persons had been killed daily. All of the 5000 Jews who had still been living in Dubno before the pogrom were to be liquidated. As the shootings had taken place in his presence he was still much upset.

Thereupon I drove to the site, accompanied by Moennikes and saw near it great mounds of earth, about 30 meters long and 2 meters high. Several trucks stood in front of the mounds. Armed Ukrainian militia drove the people off the trucks under the supervision of an SS man. The militia men acted as guards on the trucks and drove them to and from the pit. All these people had the regulation yellow patches on the front and back of their clothes, and thus could be recognized as Jews.

Moennikes and I went direct to the pits. Nobody bothered us. Now I heard rifle shots in quick succession, from behind one of the earth mounds. The people who had got off the trucks—men, women, and children of all ages—had to undress upon the orders of an SS man, who carried a riding or dog whip. They had to put down their clothes in fixed places, sorted according to shoes, top clothing and underclothing. I saw a heap of shoes of about 800 to 1000 pairs, great piles of underlinen and clothing. Without screaming or weeping these people undressed, stood around in family groups, kissed each other, said farewells and waited for a sign from another SS man, who stood near the pit, also with a whip in his hand. During the 15 minutes that I stood near the pit I heard no complaint or plea for mercy. I watched a family of about 8 persons, a man and woman, both about 50 with their children of about 1, 8 and 10, and two grown-up daughters of about 20 to 24. An old woman with snow-white hair was holding the one-year old child in her arms and singing to it, and tickling it. The child was cooing with delight. The couple were looking on with tears in their eyes. The father was holding the hand of a boy about 10 years old and speaking to him softly; the boy was fighting his tears. The father pointed toward the sky, stroked his head, and seemed to explain something to him. At that

moment the SS man at the pit shouted something to his comrade. The latter counted off about 20 persons and instructed them to go behind the earth mound. Among them was the family, which I have mentioned. I well remember a girl, slim and with black hair, who, as she passed close to me, pointed to herself and said, "23." I walked around the mound, and found myself confronted by a tremendous grave. People were closely wedged together and lying on top of each other so that only their heads were visible. Nearly all had blood running over their shoulders from their heads. Some of the people shot were still moving. Some were lifting their arms and turning their heads to show that they were still alive. The pit was already 2/3 full. I estimated that it already contained about 1000 people. I looked for the man who did the shooting. He was an SS man, who sat at the edge of the narrow end of the pit, his feet dangling into the pit. He had a tommy gun on his knees and was smoking a cigarette. The people, completely naked, went down some steps which were cut in the clay wall of the pit and clambered over the heads of the people lying there, to the place to which the SS man directed them. They lay down in front of the dead or injured people; some caressed those who were still alive and spoke to them in a low voice. Then I heard a series of shots. I looked into the pit and saw that the bodies were twitching or the heads lying already motionless on top of the bodies that lay before them. Blood was running from their necks. I was surprised that I was not ordered away, but I saw that there were two or three postmen in uniform nearby. The next batch was approaching already. They went down into the pit, lined themselves up against the previous victims and were shot. When I walked back, round the mound I noticed another truck-load of people which had just arrived. This time it included sick and infirm persons. An old, very thin woman with terribly thin legs was undressed by others who were already naked, while two people held her up. The woman appeared to be paralyzed. The naked people carried the woman around the mound. I left with Moennikes and drove in my car back to Dubno.

On the morning of the next day, when I again visited the site, I saw about 30 naked people lying near the pit—about 30 to 50 meters away from it. Some of them were still alive; they looked straight in front of them with a fixed stare and seemed to notice neither the chilliness of the morning nor the workers of my firm who stood around. A girl of about 20 spoke to me and asked me to give her clothes, and help her escape. At that moment we heard a fast car approach and I noticed that it was an SS-detail. I moved away to my site. 10 minutes later we heard shots from the vicinity of the pit. The Jews still alive had been ordered to throw the corpses into the pit;—then they had themselves to lie down in this to be shot in the neck.

← THIS IS AN EYEWITNESS ACCOUNT OF ONE OF THE METHODS USED TO MURDER MILLIONS OF GOD'S CHOSEN PEOPLE, THE JEWS. THE PHOTOGRAPH BELOW SHOWS WOMEN AND CHILDREN WAITING TO BE SHOT. I REGRET TO HAVE TO SHOW SUCH MATERIAL; BUT YOU NEED TO KNOW WHY GOD IS ABOUT TO POUR OUT HIS WRATH ON THIS WORLD. THE VERY EXISTENCE OF THE JEWS IS PROOF THAT THE BIBLE, IN HEBREW AND GREEK, IS INDEED THE WORD OF GOD. THE FACT THAT ISRAEL EXISTS ONCE AGAIN, AFTER NEARLY 2000 YEARS, SHOULD BE A WARNING THAT THE DAY OF GOD'S WRATH IS APPROACHING. THE DRAGON WILL MAKE ONE LAST EFFORT TO DESTROY THE "WOMAN". JEHOVAH, THE GOD OF THE ISRAELIS, WILL SOON COME TO DO BATTLE WITH THE ADVERSARY. (This eyewitness account is from the Encyclopedia Judaica, pages 867&868).

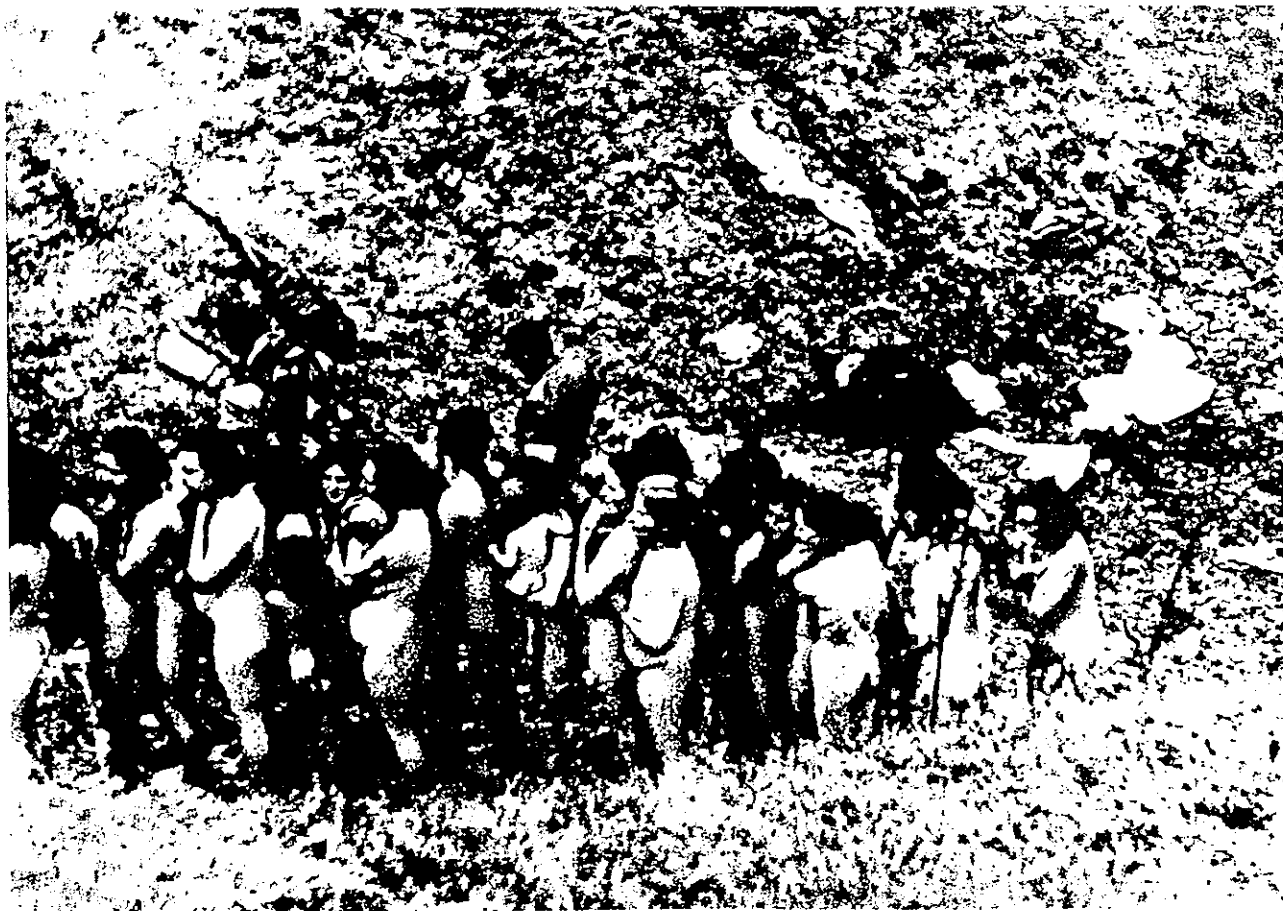

Judaica, p.862. Women, children, and babes in arms await their death. Poland. c. 1941. Courtesy Yad Vashem Archives, Jerusalem.

BABI YAR, IS THE NAME OF A RAVINE WHERE IT IS ESTIMATED THAT 100,000 PERSONS WERE MASSACRED. THE FOLLOWING RECORD IS FROM THE ENCYCLOPEDIA OF THE HOLOCAUST, VOL.1, PAGE 133.

**BABI YAR**, ravine, situated in the northwest-ern part of Kiev, where the Jews of the Ukrainian capital were systematically massacred. At the southern end of the ravine were two cemeteries, one of which was Jewish.

Kiev was captured by the Twenty-ninth Corps and the Sixth German Army on Sep-tember 19, 1941. Of its Jewish population of 160,000, some 100,000 had managed to flee before the Germans took the city. Shortly after the German takeover, from September 24

to 28, a considerable number of buildings in the city center, which were being used by the German military administration and the army, were blown up; many Germans (as well as local inhabitants) were killed in the explosions. After the war, it was learned that the sabotage operation had been the work of an NKVD (Soviet security police) detachment that had been left behind in the city for that purpose.



Babi Yar, where Sonderkommando 4a of Einsatzgruppe C carried out the mass slaughter of 33,771 Kiev Jews on September 29 and 30, 1941.

On September 26, the Germans held a meeting at which it was decided that in retaliation for the attacks on the German-held installations, the Jews of Kiev would all be put to death.

On September 28, notices were posted in the city ordering the Jews to appear the following morning, September 29, at 8:00 a.m. at the corner of Melnik and Dekhtyarev streets; they were being assembled there, so the notice said, for their resettlement in new locations. (The text had been prepared by Propaganda Company No. 637 and the notices had been printed by the Sixth Army printing press.)

The next morning, masses of Jews reported at the appointed spot. They were directed to proceed along Melnik Street toward the Jewish cemetery and into an area comprising the cemetery itself and a part of the Babi Yar ravine. The area was cordoned off by a barbed-wire fence and guarded by Sonderkommando police and Waffen-SS men, as well as by Ukrainian policemen. As the Jews approached the ravine, they were forced to hand over all the valuables in their possession, to take off all their clothes, and to advance toward the ravine edge, in groups of ten. When they reached the edge, they were gunned down by automatic fire. The shooting was done by several squads of SD and Sipo personnel, police, and Waffen-SS men of the Sonderkommando unit, the squads relieving one another every few hours. When the day ended, the bodies were covered with a thin layer of soil. According to official reports of the Einsatzgruppe, in two days of shooting (September 29 and 30), 33,771 Jews were murdered.



In the months that followed, many more thousands of Jews were seized, taken to Babi Yar, and shot. Among the general population there were some who helped Jews go into hiding, but there were also a significant number who informed on them to the Germans and gave them up. After the war, the officer in charge of the Sipo and SD bureau testified that his Kiev office received so many letters from the Ukrainian population informing on Jews—"by the bushel"—that the office could not deal with them all, for lack of manpower. Evidence of betrayal of Jews by the Kiev population was also given by Jewish survivors and by the Soviet writer Anatoly Kuznetsov.

Babi Yar served as a slaughterhouse for non-Jews as well, such as GYPSIES and Soviet prisoners of war. According to the estimate given by the Soviet research commission on Nazi crimes, 100,000 persons were murdered at Babi Yar.

In mid-August the unit embarked on its task of exhuming the corpses in Babi Yar and cremating them. The ghastly job itself was carried out by inmates of a nearby concentration camp (Syretsk), from which the Germans brought in 327 men, of whom 100 were Jews. The prisoners were housed in a bunker carved out from the ravine wall; it had an iron gate that was locked during the night and was watched by a guard with a machine gun. They had chains bolted to their legs, and those who fell ill or lagged behind were shot on the spot. The mass graves were opened up by bulldozers, and it was the prisoners' job to drag the corpses to cremation pyres, which consisted of wooden logs doused in gasoline on a base of railroad ties.

IN ORDER TO SPEED UP THE RATE OF MURDER THE GERMANS BEGAN TO USE POISON GAS. AT FIRST THEY EXPERIMENTED WITH GAS VANS WHICH WERE MOBILE. LATER THEY DEVELOPED GAS CHAMBERS IN CONNECTION WITH CONCENTRATION CAMPS. THE FOLLOWING ARE JUST A FEW NOTES FROM THE ENCYCLOPEDIA JUDAICA AND THE ENCYCLOPEDIA OF THE HOLOCAUST. FORCED LABOR, STARVATION, AND DISEASE KILLED THOUSANDS MORE.

ENCYCLOPEDIA OF THE HOLOCAUST VOL.2, P.541

**GAS VANS.** Poison gas was used by the Nazis to murder many hundreds of thousands of people. Various methods were employed, one of them being gas vans. The first time that the Nazis used gas was in the EUTHANASIA PROGRAM, in which the victims were retarded persons, the mentally or chronically ill, and habitual criminals. They were put into hermetically sealed chambers, into which carbon monoxide gas was released from metal containers. The first experiment utilizing a gas van was made in 1940, at Kochanówka, near Łódź: mentally ill children were locked inside a sealed van and put to death by the same method.

In the early stages of the war with the Soviet Union, the EINSATZGRUPPEN (mobile killing squads) killed many thousands of people by shooting. But before long the men in these units complained about the "mental anguish" they suffered from having to kill women, children, and ill people. Their superiors at the REICHSSICHERHEITSHAUPTAMT (Reich Security Main Office; RSHA) in Berlin then began to look for an alternative method of murder, one that would reduce the mental stress to which the executioners were exposed.

The first to find such a method was Arthur NEBE, the commander of Einsatzgruppe B. His men had been killing mental patients by shooting and with explosives, but these procedures had not proved satisfactory. Consequently, he tried out a technique of killing them by channeling exhaust gas from a truck into a sealed chamber, and was able to report to Berlin on the success of the experiment.

When the first gas vans were ready, in September 1941, they were tried out in the SACHSENHAUSEN camp, the victims being Soviet prisoners of war.

Following the successful tryouts, more trucks were fitted with the new apparatus, and by June 23, 1942, twenty such vehicles were in operation, with ten others in various stages of preparation. Some of the trucks, made by the Saurer firm, were larger in size, with a capacity of fifty to sixty people, while others, made by the Diamond Reo firm, had a smaller capacity of twenty-five to thirty people.

A memorandum submitted to Rauff by Willy Just of the SD, on June 5, 1942, attests to the effectiveness of the vans: "Since December 1941 . . . 97,000 persons have been processed [*bearbeitet*] with the help of three vans, without a single disruption." Some 320,000 persons were killed by this method in the Chełmno camp, most of them Jews.

Fifteen gas vans were in operation in German-occupied Soviet territory, where the Einsatzgruppen put them at the disposal of their sub-units, the Einsatzkommandos. The commander of the SS and police for REICHSKOMMISSARIAT OSTLAND in Riga had one or two gas vans for use in Latvia and Estonia and in the area between these states and the eastern war front.

Four vans were operated in Belorussia, by the commander of the SD and SICHERHEITSPOLIZEI (Security Police; Sipo) in MINSK and by Einsatzkommandos 6, 7, 8, and 9. From evidence given by the drivers and the SS men who operated the vans it is possible to reconstruct how the killing was carried out and to learn about the victims. As a rule, the gas vans served to empty prisons that had filled up with Jewish prisoners—men, women, and children—most of whom had been caught while trying to hide or escape from *Aktionen*.

Einsatzgruppe C, in the Ukraine, had five or six vans at its disposal, two used by Sonderkommando 4a, two by Einsatzkommando 6, one by the SD and Sipo commander in Kiev, and, apparently, one by Sonderkommando 4b.

In late December 1941 and early January 1942, Sonderkommando 4a liquidated the remaining Jews of Kharkov by shooting and gassing them. Some Jews had gone into hiding, and when they were discovered they were taken to the Kharkov prison and then killed in gas vans together with the prisoners. A similar method of killing prisoners was used in Kiev, as recounted by former SS-Oberscharführer Wilhelm Findeisen, the driver of a gas van for Sonderkommando 4a, at a postwar trial: "The truck was loaded in the [Sicherheitsdienst] compound, and forty people were put in—men, women, and children. I had to tell them that they were being taken to work."

I WISH FOR YOU TO GET SOME IDEA OF THE SIZE OF THIS UNDERTAKING.

**STOP AND THINK JUST A LITTLE; BEFORE YOU YOURSELF ARE BADLY DECEIVED BY THE SERPENT. WHERE DID ALL THESE PEOPLE THAT CARRIED OUT THESE ATROCITIES GO TO "CHURCH"? TODAY: AUSTRIA IS 84.3% ROMAN CATHOLIC, BELGIUM 90% ROMAN CATHOLIC, CZECHOSLOVAKIA IS 65.6% ROMAN CATHOLIC, FRANCE IS 76.4% ROMAN CATHOLIC, GERMANY IS 42.9% ROMAN CATHOLIC AND 41.6% LUTHERAN, HUNGARY IS 62.4% ROMAN CATHOLIC, ITALY IS 83.2% ROMAN CATHOLIC, AND POLAND IS 95% ROMAN CATHOLIC. ALL OF THESE ARE UNDER THE DRAGON'S AUTHORITY; THE ROMAN ECUMENICAL ASSEMBLY. (THE ENCYCLOPEDIA OF THE HOLOCAUST--BELOW)**

In the southern Ukraine, the Crimea, and Ciscaucasia (the Krasnodar and Stavropol territories), three or four gas vans were used by Einsatzgruppe D and its sub-units. By means of the vans, the Simferopol and Kerch prisons were emptied of Jews, the Jews of Sevastopol and Feodosiya were liquidated, the chronically ill and sick Jewish children in the large hospitals of the Kislovodsk and Mineralnye Vody spas were murdered, and the Jews of Piatigorsk and Cherkessk were put to death.

After several months of use in the Soviet Union, the gas vans were found to have technical deficiencies, and problems developed in their operation. In May 1942, Untersturmführer Dr. August Becker of the RSHA was sent on an inspection tour, in the course of which he visited all the Einsatzgruppen units. On his return to Berlin, he submitted a written report to the RSHA in which he singled out two major problems: (1) the mental stress on the SS men who had to unload the vans themselves, since they could not entrust prisoners with the task, lest they flee; and (2) the frequent breakdowns, caused by the poor condition of the Soviet roads. Becker's report was used as an exhibit (PS-500) by the prosecution in the postwar Nuremberg Trials.

After the war, Otto OHLENDORF, the commander of Einsatzgruppe D, testified at the SUBSEQUENT NUREMBERG PROCEEDINGS (Trial 9, The *Einsatzgruppen* Case, July 3, 1947–April 10, 1948) that Heinrich HIMMLER had given the order to kill Jewish women and children by gassing, and it was for this purpose that the vans were supplied. As it turned out, the gas vans did not meet the expectations that the Nazi leaders had had for them—to be an effective instrument for the trouble-free killing of masses of people. For that purpose, stationary gas chambers using hydrogen cyanide gas (ZYKLON B) proved speedier and more efficient. Still, the total number of victims of the gas vans was approximately 700,000, half of them in the occupied areas of the Soviet Union and the other half in the Chelmno extermination camp.

**GAS CHAMBERS**, method used by the Nazis for "efficient" mass murder. Both mobile and stationary gas chambers were put into use.

The first stationary gas chambers that were to help facilitate the "Final Solution of the Jewish question" were put up at BELŽEC, in February 1942. Following several trial gasings with carbon monoxide cylinders and exhaust gas, the latter was chosen as the better alternative, since it was cheaper and did not require special supplies. The next month, regular killings commenced at Belžec, by means of three gas chambers in a single wooden barrack. SOBIBÓR was next, in May, but here the installation was a brick building, with concrete foundations, that contained the gas chambers. The third and last of the AKTION REINHARD extermination camps in the GENERALGOUVERNEMENT was TREBLINKA, whose three gas chambers could be sealed hermetically (which was not the case in the other two extermination camps).

In the summer and fall of 1942 the capacity of the three extermination camps was greatly increased, both by enlarging the existing gas chambers and by adding new ones. Thus, in the ten gas chambers of Treblinka, twenty-five hundred persons could be put to death in a single gassing round, lasting an hour. The victims were forced to enter with their arms raised so that as many people as possible could be squeezed into the chambers. Babies and small children were thrown on top of the human mass. The tighter the chambers were packed, and the warmer the temperature inside the chamber, the faster the victims suffocated. All the gas chambers in the extermination camps were disguised as shower rooms; in Treblinka the Nazis went even further. By planting flower beds and creating what on the surface appeared to be a pleasant environment, they attempted to practice complete deception.

When the latter proved impractical, gassing experiments with ZYKLON B were made at the main camp of AUSCHWITZ, using Soviet prisoners of war, in preparation for the mass murder of Jews in the adjoining Birkenau camp.





THERE IS VERY LITTLE REASON TO ESTABLISH THESE PLACES AS MEMORIALS AS LONG AS THE "CHURCHES" ARE GOING TO TEACH LIES. TO TEACH THAT GOD IS THROUGH WITH THE JEWS, AND TO BLAME JEWS TODAY FOR KILLING JESUS; IS OF COURSE, TOTALLY FALSE. THE ADVERSARY, BY HIS "RIVER" OF ANTISEMITISM, HAS BROUGHT ABOUT THE DESTRUCTION OF MILLIONS OF GOD'S CHOSEN PEOPLE. THEN TOO, THE "CHURCH" HAS OFTEN TAUGHT THAT THEY ARE THE TRUE ISRAEL, OR EVEN THAT THEY ARE THE TRUE JEWS.

ENCYCLOPEDIA OF THE HOLOCAUST, VOL.2, P.540.

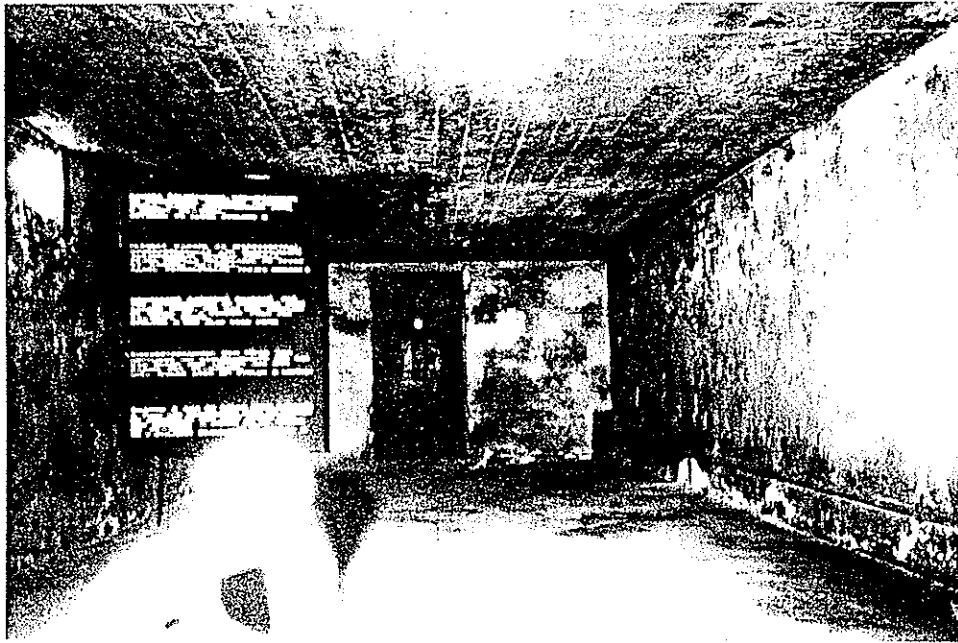

The large gas chamber at the Majdanek concentration camp. Together with other buildings, it is preserved as a Polish national memorial. [Geoffrey Wigoder]



AUSCHWITZ CONCENTRATION CAMP, JUDAICA VOL.3, P.859.

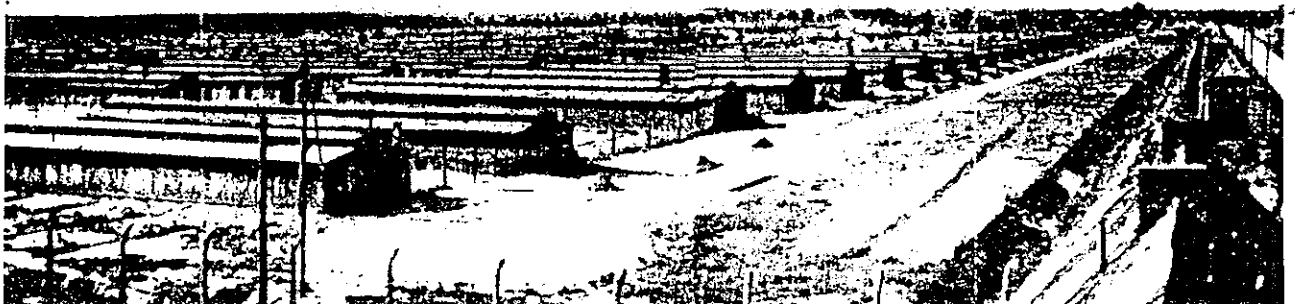

BIRKENAU CONCENTRATION CAMP, JUDAICA VOL.3, P.859.

READ A FEW OF THE REACTIONS OF THE "CHURCHES" DURING THE HOLOCAUST. REMEMBER, WE HAVE ALREADY SEEN THAT THE "CHURCH" ITSELF WAS THE GUILTY PARTY ALL THROUGH THE INQUISITION AND THE CRUSADES.

ENCYCLOPEDIA OF THE HOLOCAUST VOL.1, P.291.

Christian anti-Judaism derives from the earliest years of the Christian community, when the majority of Jews refused to accept the supernatural claims made for the person of Jesus of Nazareth. Its character changed in the fourth century, by which point most Christians were gentiles and Christianity became the state religion of the Roman empire. The theologians of the fourth and fifth centuries codified and extended anti-Judaic hostility by claiming that all Jews, as a community, shared the blame for the crucifixion of Jesus, that the destruction of Jerusalem in the year 70 was a divine punishment, that the Jewish people were to be treated with severity because of their obstinate blindness in refusing the promises made in their own traditional scriptures, and that the church had now superseded Judaism as the vehicle for salvation. These themes became the basis of traditional Christian teachings for many centuries, providing theological justification for repeated acts of persecution and violence. Despite the fact that successive popes issued edicts that Jews were to be considered witnesses of the original truth of divine relation to man—and, as such, regarded as potential converts—the triumphalist and monopolistic views of orthodox Christianity led to the imposing of social and physical segregation on the Jewish communities in ghettos or as minorities throughout Christian Europe; to widespread expulsions of Jews from Christian countries such as Spain and England; and to the repressive and often murderous policies of the Catholic Inquisition.

The influence of Martin Luther, especially in his rabid diatribes against the Jews at the end of his career, carried over the same theological antipathies into Protestantism, and contributed to the frequent persecution and the expulsions of Jews from German territories and city-states during the Reformation. Some of the followers of John Calvin, however, demonstrated a warmer sympathy for the Jews as the originators of Hebraic morality and of the sacred scriptures.

The rise of secularist thought in the eighteenth century, and of romanticism in the nineteenth, led to increasing skepticism in western Europe about traditional Christian dogmatic teachings, including Christian attitudes toward Judaism. The ingrained religious prejudices, however, remained entrenched in popular culture, especially in

eastern Europe. Other forms of antisemitism, based on social, economic, or national ideas, increasingly came to overlap and supersede theological antipathies, adapting the stereotypes of earlier centuries and infusing the religious vocabulary with political and racist connotations. This incremental process was notable in the antisemitic propaganda of the early twentieth century, and in the formation of explicitly antisemitic political parties in Germany, France, and Austria. Only isolated Christian protests were voiced against the extremism of these racist views—notably the writings of the Protestant theologian Karl BARTH and Pope Pius XI's 1938 statement, "Antisemitism is inadmissible. We are all spiritually Semites."

Christian theology provided no adequate defense against the escalating violence and mass murders of the Holocaust.

Roman Catholicism. Catholic attitudes toward the Nazi persecution of the Jews were ambivalent throughout the period of the Third Reich. The new Nazi regime's signature of a Reich Concordat with the Vatican in July 1933, and German Catholic support for its authoritarian and nationalist stances, gave rise to widespread illusions about the nature of Hitler's rule, illusions that were to be much criticized in the aftermath. This early collaboration preempted the possibility of mobilizing German Catholic opposition to the regime, even when the Nazis' pursuit of their totalitarian goals led to the increasing abrogation of the Concordat and persecution of the church. Despite the condemnation of Nazi ideology and RACISM in general in the papal encyclical *Mit brennender Sorge* (With Burning Concern) of March 1937, German Catholic sympathy for the Jews was evident only in individual cases, notably for Catholics of Jewish origin. Opposition was expressed more toward the methods employed by the Nazis than toward their repressive policies. The attitudes of such leading Catholics as the presiding bishop, Cardinal Adolf Bertram of Breslau, were characterized by deep-rooted hostility to the Jews, strong expressions of national loyalty, and the desire to protect their own church institutions. They led to silent acquiescence in face of the NUREMBERG LAWS of 1935 and the KRISTALL-NACHT pogrom of 1938.

THE ENCYCLOPEDIA OF THE HOLOCAUST WAS PUBLISHED BY MACMILLAN PUBLISHING COMPANY, NEW YORK, IN 1990 IN 4 VOLUMES. YOU SHOULD BE INFORMED, AT LEAST IN A SMALL MEASURE, IN REGARDS TO SOME OF THE INVOLVEMENT OF THE UNITED STATES. THIS PAGE AND SOME FOLLOWING MATERIAL IS NOT ON THE CASSETTES. HIGHLIGHTS ARE UNDERLINED.

ROOSEVELT, FRANKLIN DELANO (1882–1945), thirty-second president of the United States. Roosevelt's unprecedented four-term administration (1933–1945) began with the end of the collapse of the world economy known as the Great Depression, and ended with the events of World War II, which witnessed the destruction of European Jewry. He was the world leader in the best position to attempt the rescue of the Jews of Europe, but, according to many historians, his actions fell short of what might have been done.

For American Jewry that failure was a special disappointment since they supported Roosevelt enthusiastically. The shift of Jews to the Democratic party, which began in earnest in 1924, brought them closer to Roosevelt, whose political career up until then was confined to that party's New York State branch. In the presidential elections of 1932 and 1936, Jews gave him an overwhelming percentage of their votes, and by the 1940 election nine out of ten Jews were casting their ballots for him.

Roosevelt's New Deal program matched the social-democratic proclivities of the majority of Jewish voters and accounts for their great loyalty to him. But this unity of outlook was not present when it came to the specific Jewish interest in a more effective rescue policy during the Holocaust period. It is true that Roosevelt instructed American consuls, who made the final judgments on who should receive visas, to show "special concern" for Jewish refugees, and that he called home his ambassador to Germany in a gesture of dismay after KRISTALLNACHT (November 9–10, 1938), then permitting those Jews who had entered the United States on visitor's visas to extend their stay. Yet he did not generally alter the administration of the "Likely to Become Public Charge" (LPC) provision of the immigration law. This directive, introduced by President Herbert Hoover, was so rigidly enforced that in most depression years there was a net loss of immigrants. Only in 1939 were the applicable quotas fully utilized. More important, the policy of doing nothing concrete to help the Jews of Europe created a momentum for inaction that continued into the phase when they were being subject to mass killings. In that period, virtually every suggestion—including the sending of food packages, retributive bombing, changing the

designation of camp inmates to that of prisoners of war, and filling the holds of empty ships returning to the United States with refugees—was rejected. These rejections emanated from the State Department (see UNITED STATES DEPARTMENT OF STATE) and War Department in particular, as well as from smaller government branches such as the Office of War Information.

After the ANSCHLUSS, Roosevelt made a half-hearted attempt to solve the growing refugee problem at its source. In July 1938, thirty-two nations were invited to meet at Evian-les-Bains. But Jewish rescue advocates watched in dismay as the delegations refused to accept any responsibility for the problem. The American delegation, headed by Myron Taylor, announced that its own restrictive immigration laws were sacrosanct and that no differentiation could be made between an ordinary immigrant and a refugee in dire need of a haven. Although Roosevelt had called the refugee conference, the United States declined to set an example that other nations might have followed.

The two agencies that grew out of the EVIAN CONFERENCE, the INTERGOVERNMENTAL COMMITTEE ON REFUGEES (IGCR), designed to coordinate the international effort, and the PRESIDENT'S ADVISORY COMMITTEE ON POLITICAL REFUGEES (PAC), set up to coordinate the domestic effort, remained totally ineffective throughout the crisis and were monuments to the Roosevelt administration's "politics of gestures." The conference was designed more to placate the rescue advocates than it was to save the victims of the Holocaust.

The Roosevelt administration supported a policy of mass resettlement, giving publicity, for example, to a scheme to resettle thousands of European Jews in the Dominican Republic through the Dominican Republic Resettlement Association (DORSA). It supported British efforts to settle Jews in British Guiana, a locale of previous failures to do so. Hundreds of other areas, usually unsuitable or unavailable, were investigated by various agencies in the administration, and all but DORSA came to naught (DORSA succeeded in resettling 500 Jews in the Dominican Republic).

When public pressure in face of the "FINAL SOLUTION" reached a crescendo in the early months of 1943, Roosevelt joined with the British to convene a second refugee conference, on the island of Bermuda, in April 1943.

THIS PAGE CONTINUES WITH INFORMATION THAT YOU SHOULD READ. THE PURPOSE OF MY INSERTING THESE ITEMS IS TO DEMONSTRATE THAT ALL NATIONS HATE THE JEWS; AND YET AT THE SAME TIME THESE THINGS GIVE MORE EVIDENCE THAT PROVES THE BIBLE TO BE TRUTH.

The BERMUDA CONFERENCE was a particularly bitter experience for rescue advocates. As with previous gatherings, its results were virtually nonexistent and were dismissed by rescue advocates as a "hollow mockery."

➤ Only in January 1944 did Roosevelt permit some deviation from wartime priorities to make a modest gesture in the cause of the rescue of the Jews. As a result of a special plea by his secretary of the treasury, Henry MORGENTHAU, Jr., who presented evidence of the State Department's systematic sabotage of the rescue effort, the WAR REFUGEE BOARD (WRB) was established. That agency's sometimes imaginative but often reluctant efforts to save the Jews of HUNGARY, the only sizable Jewish community remaining in Europe, came too late to make an appreciable difference. In April of that year, there occurred at Roosevelt's behest a circumvention of the supposedly immutable immigration laws. More than nine hundred predominantly Jewish refugees were admitted and housed in FORT ONTARIO, at Oswego, New York. But this was a symbolic rather than a substantive victory, and only demonstrated what could have been done had there been a will to save lives.

There were, of course, many reasons why Roosevelt chose not to act, but behind them all was his failure to fathom what the Holocaust signified for his own time in history. Preoccupied with the war and in failing health, Roosevelt was only peripherally aware of the destruction of European Jewry, which he perceived simply as an unpleasant fact.

**UNITED STATES DEPARTMENT OF STATE,** the United States governmental body most directly responsible for dealing with the fate of European Jewry during the interwar period and, to a certain extent, during the war, through its powers to grant visas, formulate refugee policy, and deal with foreign governments and international agencies. It has come under severe criticism for its lack of response to the destruction of European Jewry.

The State Department's career officers were traditionally part of an upper-class elite and were insensitive, and often antagonistic, to non-"Anglo-Saxon" immigrants. This helped shape their response to the events of the Holocaust, at a time when much of the department's policy formulation was in their hands.

➤ After Hitler's accession to power in 1933, as the plight of German Jewry grew increasingly difficult, American consuls in Germany often added to the already stringent United States visa regulations, creating extreme difficulties for German Jews trying to obtain United States entry visas. In this, and in its opposition to increasing the number of REFUGEES permitted to enter the United States, the State Department reflected the prevalent public view on relaxing the immigration restrictions.

The State Department's attitude toward the plight of the refugees hardened when, in ➤ January 1940, Breckinridge Long, a political associate of President Franklin D. ROOSEVELT, was appointed assistant secretary of state, with authority over the Visa Division and responsibility for formulating United States refugee policy. Out of fear of spies and saboteurs infiltrating among the refugees, and out of a desire to prevent the United States from being inundated by elements (both ethnic and political) perceived as undesirable, Long raised further the barriers to refugees from Europe.

In the summer of 1942, the State Department attempted to prevent news of the Holocaust, transmitted through its channels, from reaching American Jewish leadership (see RIEGNER CABLE). In February 1943, the State Department gave specific instructions to its representative in Switzerland not to transmit such information. When President Roosevelt acquiesced to the Jewish leadership's request to allow the transfer of funds to the Jews of Romania, the State Department delayed the transaction. Throughout the war it opposed any serious rescue or relief efforts for the Jews of Europe.

The apparent apathy of State Department officers toward the fate of the European Jews led top officials of the Treasury Department to accuse them, in a report to the president, of deliberate acquiescence in the murder of the Jews of Europe. This report was the major factor in Roosevelt's decision to create the WAR REFUGEE BOARD, which subsequently made the main decisions regarding relief and rescue attempts.

➤ **SEE PAGE 60. IF THE U.S. INTELLIGENCE DID NOT KNOW OF THE PLIGHT OF THE JEWS TILL 1942-3 IT WAS NO WONDER U.S. WAS NOT PREPARED FOR PEARL HARBOR.**

# JESUS IS SPEAKING TO JEWS, NOT GENTILES.

## MATTHEW 24 CT

7 For nation will-be-raised over nation and kingdom over kingdom; and famines and pestilences and earthquakes will-be according-to places.

8 But all these-*things are* beginning of-birth-pains.

9 Then they-will-give YOU over into tribulation, and they-will-kill YOU; and YOU-will-be being-hated by all the Gentiles because-of my name.

IN 1944 THE WOMAN, ISRAEL, WAS ONLY 4 YEARS FROM DELIVERY.

**AUSCHWITZ, BOMBING OF.** By the spring of 1944, the massive killing operations under way at AUSCHWITZ were well known to the Allied governments (see AUSCHWITZ PROTOCOLS). By that time the Allied air forces controlled the skies of Europe and clearly had the range to strike Auschwitz as well as the railways leading to it. Yet no effort was made to bomb the gas chambers or the deportation railways, despite numerous requests for such action.

Great Britain's Prime Minister Winston CHURCHILL and Foreign Secretary Anthony EDEN supported a proposal made by the Jewish Agency for Palestine to bomb Auschwitz and the railways to it. But officials in the British Air Ministry and the Foreign Office managed, by stalling, to choke the plan to death, without ever looking carefully into its feasibility. The official British reply to the Jewish Agency dishonestly stated that "technical difficulties" made the proposed operations impossible (see GREAT BRITAIN).

The United States government also received requests, mostly from Jewish sources, to smash the Auschwitz killing installations and the railways to Auschwitz. These proposals became numerous in the spring of 1944, as the deportation of the large Hungarian Jewish community began. The first of the requests was turned down by the United States War Department in late June 1944 on the ground that "it could be executed only by diversion of considerable air support essential to the success of our forces now engaged in decisive operations."

In reality, the War Department's negative decision was not based on any analysis of air force operations. The department never looked into the feasibility of carrying out such bombing operations; it did not even consult the air force commanders based in Italy who were in the best position to strike Auschwitz.

What happened was that the War Department officials, when first confronted with the issue in June 1944, looked into their own files in Washington. There they found that several months earlier, the War Department had secretly established a policy of noninvolvement in rescue activities. This policy had come in response to President Franklin D. ROOSEVELT's formation of the WAR REFUGEE BOARD (WRB) in January of that year. The president's executive order establishing the WRB had specified that the State (see UNITED STATES DEPARTMENT OF STATE), Treasury, and War departments each had a special responsibility to help the WRB in its rescue endeavors. War Department officials, alarmed that this might mean that military forces would be diverted to rescue missions, unilaterally decided on a policy of noninvolvement in rescue. This was done despite awareness that it was in violation of the president's executive order. The policy was kept secret.

When the first bombing request came to the War Department, forwarded through the WRB, War Department officials checked their files and found the department's no-rescue policy. On that basis they decided against the proposal, without even looking into its feasibility. Obviously, they could not inform the WRB of the real reason for rejecting the bombing request. Instead, they used the best argument available: that it would divert military power from essential war operations.

With this, the die was cast. Each of the several succeeding requests to bomb the gas chambers and the railways was rejected for the same reason as the first. The last such request was turned down in mid-November 1944. It is now known that these bombings were definitely within the capability of the United States Air Force based in Italy; in fact, they could have been accomplished in connection with essential war operations.



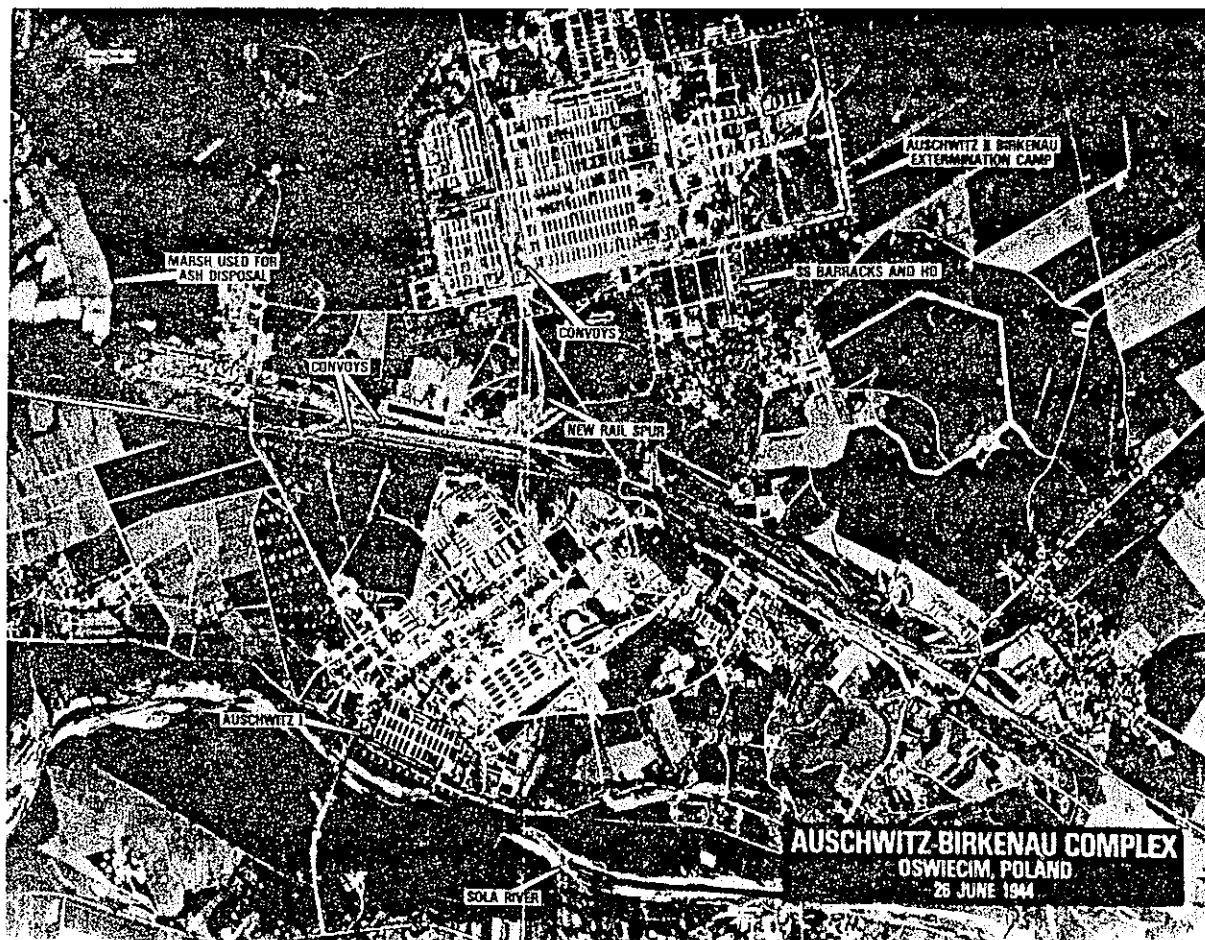

Aerial bombing map of Auschwitz used to plan runs over Auschwitz by United States forces. The industrial areas were targeted, leaving the railway lines to the camp intact. [A Living Memorial to the Holocaust—Museum of Jewish Heritage, New York]

Because the Auschwitz complex included a major industrial area adjacent to the camp, Auschwitz itself was a military target. The primary objective there was a synthetic oil refinery. The Germans had seven other synthetic oil plants in the region, all based on all within 45 miles of Auschwitz. From July through November 1944, more than twenty-eight hundred American heavy bombers pounded the eight oil installations. En route to their targets, all these aircraft flew along or over key deportation railways. On two occasions (August 20 and September 13), large fleets of American bombers struck the industrial area at Auschwitz itself, less than 5 miles from the four huge gas chamber installations.

Yet on August 14, 1944, the War Department insisted, in a letter to Leon Kubowitzki (Aryeh Kubovy) of the World Jewish Congress, that bombing the Auschwitz killing installations and the deportation railways was not possible because such actions "could be executed only by the diversion of considerable air support essential to the success of our forces now engaged in decisive operations elsewhere." This was a word-for-word repetition of the June refusal. It was at variance with the facts and was no more than an excuse for inaction.

SEE PAGE 61 .

IF YOU WANT TO SUBSCRIBE,  
PLEASE TELEPHONE 4-6877  
Litho., Printing, Binding, Distribution  
**CARL MARX**  
15 FIFTH AVENUE, NEW YORK 17

May 16, 1948  
NEW YORK  
OFFICE, MAY 15, 1948

**THE PALESTINE  
POST**

PRICE: 10 CENTS  
VOL. XXIV, No. 214

**THE PALESTINE  
POST**  
THIS SUBSCRIPTION DEPARTMENT  
is connected to The Palestine Post  
office, 15th Street,  
Jerusalem, Tel. 688.

**STATE OF ISRAEL IS BORN**

REVELATION 12 CT

1 And a great sign was-seen in the heaven, a woman having-been-and-still-cast-around with the sun, and the moon underneath her feet and on her head a crown of stars twelve.  
2 And having in her womb, and suffering-birth-pains she is-crying and being-tormented to-bring-forth.

**GOD'S FIRST "ROADBLOCK".**  
"WOMB", IS NEVER CONFUSED WITH "BELLY"; AND DELIVERY DOES NOT OCCUR FROM THE "WOMB".

5 And she-brought-forth a son, a male, who is-about to-be-shepherding all the Gentiles with an iron rod; and her child was-seized to the God and to his throne.

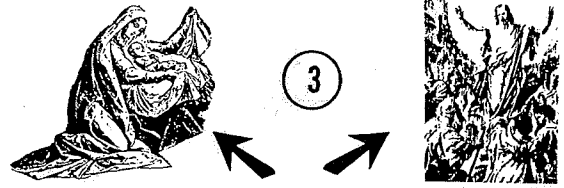
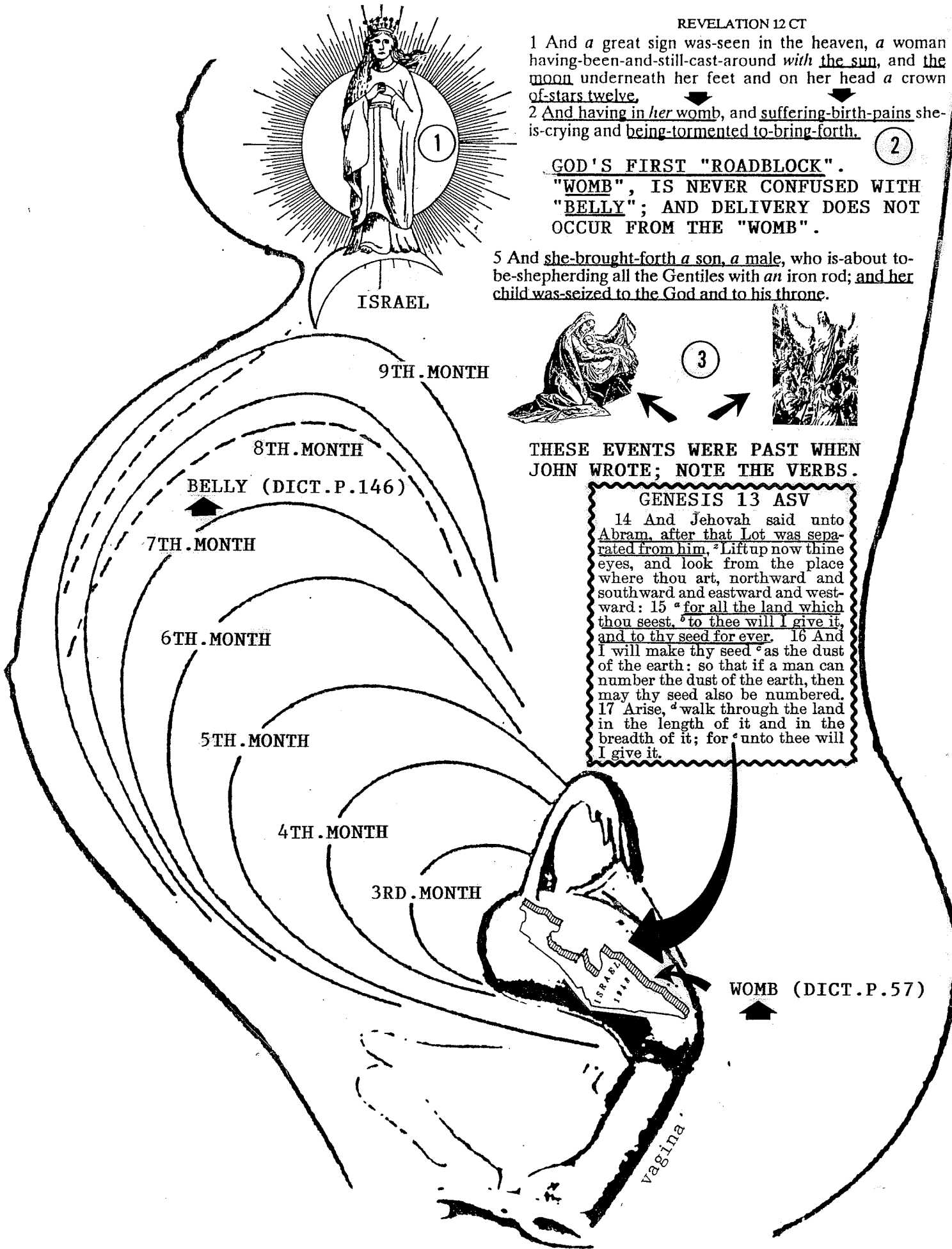

THESE EVENTS WERE PAST WHEN JOHN WROTE; NOTE THE VERBS.

**GENESIS 13 ASV**  
 14 And Jehovah said unto Abram, after that Lot was separated from him, "Lift up now thine eyes, and look from the place where thou art, northward and southward and eastward and westward: 15 "for all the land which thou seest, "to thee will I give it, and to thy seed for ever. 16 And I will make thy seed "as the dust of the earth: so that if a man can number the dust of the earth, then may thy seed also be numbered. 17 Arise, "walk through the land in the length of it and in the breadth of it; for "unto thee will I give it.

WOMB (DICT.P.57)

REVELATION 12:4 CT

And the dragon has-stood-and-still-stands in-sight of the woman namely-the future one to-bring-forth, in-order-that at-the-time-that she-might-bring-forth he-might-devour her child.

**GOD'S SECOND "ROADBLOCK".**  
THE WOMAN, ISRAEL, IS STILL PREGNANT. NOTE THE VERBS. WE CAN CONCLUDE THAT THIS PREGNANCY IS FIGURATIVE. (PAGE 29)

**GOD'S THIRD "ROADBLOCK".**  
"DEVOUR" IS NOT USED IN THE SENSE OF EATING; BUT IN THE SENSE OF CONSUME, RAVAGE, PLUNDER OR LOOT. SEE MATT.23:13, AND GAL.5:15. WE CAN CONCLUDE THEN, THAT THIS CHILD IS NOT A LITERAL CHILD.

REVELATION 12 CT

6 And the woman fled into the wilderness, where-in-which she-is-having there a place having-been-and-still-prepared from the God, in-order-that there they-might-be-nourishing her a thousand two-hundred sixty days.

**GOD'S FOURTH "ROADBLOCK".**  
VERSE 6 FOLLOWS VERSE 5, AND TAKES PLACE AFTER JESUS WAS CAUGHT UP TO GOD'S THRONE. THIS FLIGHT IS EXPLAINED ON PAGES 2&3 IN APOLOGETICS 25. IT OCCURRED IN 66A.D. AND LASTED TILL 70A.D.

REVELATION 12 CT

7 And it-came-to-pass a war in the heaven, the Michael and his angels to-war with the dragon. And the dragon warred and his angels.  
8 And he-was not strong-enough, neither was their place still found in the heaven.  
9 And the dragon, namely-the great one, namely-the serpent, namely-the ancient one, the one being-called a slanderer, also the adversary, namely-the one leading- astray the total inhabited-earth, was cast, he-was-cast into the earth, and his angels were-cast with him.

LUKE 10 CT

17 But the seventy returned with joy, saying, Lord, even the little-demons are-themselves-being-subject to-us in your name. \*  
18 But he-said to-them, I-was-observing the adversary as a-beam-of-light having-fallen out-of the heaven.

\* THESE LITTLE-DEMONS WERE SATAN'S ANGELS. SEE DISCOURSE 5, PAGE 25. THE TEACHING DICTIONARY, PAGE 428.  
I BELIEVE SATAN WAS CAST OUT OF HEAVEN AFTER JESUS REJECTED SATAN'S OFFER OF THE AUTHORITY OVER THE INHABITED-EARTH, THE ROMAN EMPIRE.

LUKE 4 CT

5 And the slanderer having-led him up into a high mountain he-pointed-to all the kingdoms-of-the inhabited-earth for-him in a point of-time.

THEN CAME THE CRUCIFIXION.

REVELATION 12 CT

10 And I-heard a great voice in the heaven saying: Just-now came-to-pass the salvation and the power and the kingdom-of-our God and the authority-of-his Messiah, because the accuser-of-our brothers was-cast-down, the one accusing them in-sight-of-our God of-day and of-night. 11 And they themselves-had-victory-over him because-of the blood-of-the Lamb and because-of the word-of-their witness, and they-cherished not their soul unto death. 12 Because-of this YOU-be-being-merry-for-yourselves, heavens and the ones tabernacling in them; woe to-the ones residing on the earth and the sea, because the slanderer descended to YOU having great anger, knowing-absolutely that he-is-having a little-bit season.

WE NOW HAVE FURTHER IDENTIFICATION OF THE WOMAN, NAMELY THE ONE WHO BROUGHT FORTH JESUS. THE WOMAN IS ISRAEL; ANY OTHER IDENTIFICATION IS IMPOSSIBLE AND FALSE.

REVELATION 12 CT

13 And when the dragon saw that he-was-cast into the earth, he-pursued the woman, one-who brought-forth the male.

THE FIGURATIVE WOMAN, ISRAEL, NOW FLEES A SECOND TIME; STILL BEARING A FIGURATIVE CHILD. SHE IS STILL SUFFERING-BIRTH-PAINS. REV.12:2.

MARK 13 CT

7 But at-the-time-that YOU-might-hear wars and reports of-wars, YOU-be not being-alarmed; for it-is-essential to-come-to-pass, BUT not-yet the finish.  
8 For nation will-be-raised upon nation and kingdom upon kingdom; and earthquakes will-be according-to places, and there-will-be famines and disturbances. These-things are beginnings-of-birth-pains.

MATTHEW 24 CT

7 For nation will-be-raised over nation and kingdom over kingdom; and famines and pestilences and earthquakes will-be according-to places.  
8 But all these-things are beginning-of-birth-pains.  
9 Then they-will-give YOU over into tribulation, and they-will-kill YOU; and YOU-will-be being-hated by all the Gentiles because-of my name.

JESUS HIMSELF WARNED OF THE BIRTH-PAINS. FOR WHAT OTHER REASON WOULD JESUS USE THE WORD BIRTH-PAINS IN RELATION TO WORLD WARS?

REVIEW PAGES 57 THROUGH 72.

WHAT THEN, WAS IN THE WOMAN'S WOMB? GOD'S PROMISE TO ABRAM. SHALL A LAND BE BORN IN ONE DAY? ISAIAH 66:8 ASV.

MATTHEW 8 CT

11 But I-am-saying to-YOU, that many will-be-present from risings and settings, and they-will-be-reclined-again with Abraham and Isaac and Jacob in the kingdom-of-the heavens;

THUS FAR YOU HAVE SEEN PROOF THAT THE JEWS HAVE BEEN GOD'S CHOSEN PEOPLE FROM THE TIME HE CALLED THEM OUT OF EGYPT. SCRIPTURE HAS ONLY BEEN GIVEN TO US, THAT IS GENTILES, BY THE JEWS. THE VERY FACT THAT ISRAEL IS AGAIN ON THE MAPS OF THE WORLD SHOULD BE PROOF THAT THE JEWS ARE GOD'S CHOSEN. THE RESTORATION OF THE HEBREW LANGUAGE IS FURTHER PROOF. LET ME ONCE AGAIN CALL YOUR ATTENTION TO AN EVER PRESENT FACT.

The one leading—astray the total inhabited—earth,  
 ὁ σατανᾶς, the adversary, the dragon, the great,  
 ὁ διάβολος, the slanderer, the serpent, the ancient.

NEXT CONSIDER SOME, EASY TO UNDERSTAND, OLD TESTAMENT VERSES. THESE VERSES ARE EASY UNLESS YOU ARE ONE OF THOSE WHO ARE BEING LED ASTRAY BY THE DRAGON. HOW MUCH AUTHORITY, AND OVER WHAT OR WHOM DOES HE HAVE THAT AUTHORITY? THE BIBLE SAYS THAT; HE IS LEADING—ASTRAY THE TOTAL INHABITED EARTH. AS I HAVE ALREADY SHOWN; THE INHABITED—EARTH IS NOT THE "WORLD"; BUT RATHER, THE ROMAN ECUMENICAL ASSEMBLY, THAT IS, THE 7TH WORLD POWER.

#### HOSEA 3 ASV

**3** And Jehovah said unto me, "Go again, love a woman beloved<sup>17</sup> of her friend, and an adulteress, even as Jehovah loveth the children of Israel, though they turn unto other gods, and<sup>18</sup> love °cakes of raisins. 2 So I<sup>2</sup> bought her to me for fifteen pieces of silver, and a homer of barley, and a<sup>19</sup> half-homer of barley; 3 and I said unto her, Thou shalt abide for me many days; thou shalt not play the harlot, and thou shalt not be any man's wife: so will I also be toward thee. 4 For the children of Israel shall abide many days<sup>2</sup> without king, and without prince, and<sup>1</sup> without sacrifice, and without<sup>20</sup> pillar, and without °ephod or °teraphim: 5 afterward shall the children of Israel<sup>2</sup> return, and seek Jehovah their God, and °David their king, and shall<sup>2</sup> come with fear unto Jehovah and to his goodness in the latter days.

#### HEBREWS 10 CT

16 This is the covenant which I-myself-shall-covenant with them after those days, Jehovah is saying: Giving my laws on their hearts, and on their intellects I-shall-inscribe them,  
 17 And of-their sins and their lawlessnesses I-shall by-no-means still be-mindful.

GOD IS BRINGING HOSEA 3:4 TO A CLOSE.  
 MANY WHO BELIEVE THE BIBLE ARE ASKING;  
 WHAT PROPHECIES WILL BE FULFILLED NEXT?

## Second Time

THERE IS NO THIRD.

DAVID WILL BE  
 HERE AS KING.  
 APOLOGETICS 40

#### ISAIAH 11 ASV

11 And it shall come to pass in that day, that the Lord °will set his hand again the second time to °recover the °remnant of his people, that shall remain, from °Assyria, and from °Egypt, and from Pathros, and from Cush, and from °Elam, and from Shinar, and from Hamath, and from the °islands of the sea.

#### JEREMIAH 31 ASV

31 °Behold, the days come, saith Jehovah, that I will make a °new covenant with the house of Israel, and with the house of Judah: 32 not according to the °covenant that I made with their fathers in the day that I °took them by the hand to bring them out of the land of Egypt; °which my covenant they °brake, although I was °a °husband unto them, saith Jehovah. 33 But °this is the °covenant that I will make with the house of Israel after those days, saith Jehovah: I will put my law in their inward parts, and in their °heart will I write it; and I will be their God, and they shall be my people: 34 and they shall °teach no more every man his neighbor, and every man his brother, saying, Know Jehovah; for they shall all °know me, from the least of them unto the greatest of them, saith Jehovah: for I will °forgive their iniquity, and their °sin will I remember no more.

TO TALK ABOUT "CASTING OUT SATAN" IS FOOLISHNESS; BECAUSE GOD HAS GIVEN HIM CERTAIN AUTHORITY. I HAVE CERTAINLY GIVEN YOU PROOF THAT HE HAS BEEN GIVEN AUTHORITY AGAINST THE JEWS IN DISPERSION. THE RIVER OF ANTISEMITISM FLOWS FROM THE SERPENT AND THE DRAGON. STUDY THE PICTURE ON PAGE 28A CAREFULLY.

USING 8 OF THE OFTEN USED TRANSLATIONS OF THE NEW TESTAMENT; I HAVE CERTAINLY PROVED THAT SATAN HAS DONE A "GOOD JOB" IN CONFUSING THE ENGLISH TRANSLATIONS OF GOD'S WORD BY HIS MINISTERS IN THE "CHURCHES". (PAGES 2,3,4,6,7,9,10,22,24,25,40, AND 53.)

A WARNING: IF YOU ARE IN THE ROMAN CATHOLIC CHURCH, YOU ARE IN SATAN'S KINGDOM. THE POPES ARE THE RULING EMPERORS, EXACTLY AS THE EMPERORS OF ROME. THE CORRUPTION OF THE POPES IS SHOWN VERY BRIEFLY ON PAGES 37,38,51, AND 52. ON PAGE 53 I HAVE SHOWN THAT IT IS GOD WHO DID THE CORRUPTING; EVEN AS GOD HAS DONE IN RECENT DAYS AMONG SOME "EVANGELISTS". FOR MUCH MORE ON THE PAPAL EMPIRE, REFER TO APOLOGETICS 23,24,25,33,34, AND 35.

THE ROMAN CATHOLIC CHURCH CLAIMS TO BE THE "BRIDE" OF CHRIST. WHEN THE PROTESTANT CHURCHES WERE FORMED AS A BREAK FROM THE ROMAN CATHOLIC CHURCH, DURING THE PERIOD CALLED THE REFORMATION; THEY ALSO CLAIMED TO BE THE "BRIDE". AT NO TIME IS THE "CHURCH" CALLED THE BRIDE IN THE NEW TESTAMENT. THE BRIDE IS ISRAEL.

THE MIDRASH RABBAH, DEUTERONOMY PAGE 65.

R. Berekiah said: In the following ten places in Scripture God refers to Israel as a bride: *Come with Me from Lebanon, my bride (S.S. IV, 8); I am come into my garden, my sister, my bride (ib. V, 1); Thou hast ravished my heart, my sister, my bride (ib. IV, 9); How fair is thy love, my sister, my bride (ib. 10); Thy lips, O my bride, drop honey (ib. 11)<sup>3</sup>; And as the bridegroom rejoiceth over the bride (Isa. LXII, 5); The voice of the bridegroom and the voice of the bride (Jer. VII, 34); Thou shalt surely clothe thee with them all as with an ornament, and gird thyself with them, like a bride (Isa. XLIX, 18); And as a bride adorneth herself with her jewels (ib. LXI, 10).*

THE SONG OF SOLOMON WAS WRITTEN 1000 B.C. AND BELONGS TO ISRAEL. THE "CHURCH" TAKES ALL THESE VERSES TO PROVE THAT THE "CHURCH" IS THE BRIDE. NEITHER THE WORD BRIDE NOR BRIDE-GROOM EVER OCCUR IN REFERENCE TO THE NEW TESTAMENT "CHURCH".

APOLOGETICS 10

A FINAL QUESTION: HOW FAR DOES THE AUTHORITY OF THE ADVERSARY REACH BEYOND THE ROMAN ECUMENICAL ASSEMBLY? FURTHER, PERHAPS, THEN YOU MIGHT THINK. TODAY WE READ ABOUT ECUMENISM; WHAT DOES IT MEAN? THE READER'S DIGEST DICTIONARY SAYS: 1. A MOVEMENT OR DOCTRINE PROMOTING UNITY AMONG THE CHRISTIAN CHURCHES. 2. A MOVEMENT OR DOCTRINE PROMOTING WORLDWIDE UNITY AMONG RELIGIONS THROUGH GREATER COOPERATION AND IMPROVED UNDERSTANDING. THE ADVERSARY IS CERTAINLY MAKING GREAT PROGRESS.

THE LINK BETWEEN RELIGIONS IS THE EUCHARIST, COMMUNION, OR THE LORD'S SUPPER. REFER TO PAGES 39 AND 43. IN DISCOURSE 3, IT WAS SHOWN HOW THE PASSOVER WAS REPLACED IN THE 7TH WORLD EMPIRE BY THE PAGAN "BREAD AND WINE".

ISRAEL IS TO KEEP THE PASSOVER FOREVER. (EXODUS 12:24) ON PAGE 54 YOU WERE SHOWN THAT GENTILES ARE GRAFTED INTO ISRAEL; NOT ISRAEL INTO THE "CHURCH". THEREFORE, IF ISRAEL IS TO KEEP THE PASSOVER FOREVER; A JEW WHO RECEIVES JESUS AS HIS MESSIAH AND HIS SAVIOR SHOULD CONTINUE TO KEEP THE PASSOVER. GENTILES GRAFTED INTO THE ROOT SHOULD DO LIKEWISE. JESUS HIMSELF KEPT THE PASSOVER. SATAN, WHO'S REAL NAME IS ZEUS, BROUGHT IN THE BREAD AND WINE. SEE PAGES 16,19,34 AND 35; AS WELL AS APOLOGETICS 42.



37 Jerusalem, Jerusalem, the-one killing the prophets and casting-stones-at the-ones having-been-dispatched-and-still-being-dispatched to her, how-often I-willed to-gather-together-completely your children, which manner a hen is-gathering-together-completely the chicks of-herself under the wings, and YOU-willed not:

38 Behold, YOUR home, desolate, is-being-let-be to-YOU;

39 For I-am-saying to-YOU, By-no-means might-YOU-see me from just-now till YOU-might-say, Having-been-blessed-and-still-blessed is the-one coming in the name of-Jehovah.

A FLAG DISPLAYED BECAUSE OF THE TRUTH. PSALMS 60:4.



## HEBREWS 8 CT

7 For if that first *covenant* was faultless, a place was not being-sought of-a-second.

8 For finding-fault with-them he-is-saying: Behold days are-coming, Jehovah is saying, and I-shall-finish-completely upon the household of-Israel and upon the household of-Judah a new-quality covenant,

9 Not according-to the covenant which I-made to-their fathers in a day of-my having-taken-hold of-their hand to-lead them out-of the land of-Egypt, because they themselves remained not in my covenant, and I myself neglected of-them, Jehovah is-saying.

10 Because this is the covenant which I-shall-myself-covenant to-the household of-Israel after those days, Jehovah is-saying, giving my laws into their intellect, and I-shall-inscribe them on their hearts, and I-shall-be to-them with-reference-to God and they themselves will-be to-me with-reference-to a people.

11 And they-might not teach each *one* his citizen and each *one* his brother, saying: You-come-to-know the Lord, because they-will all know me absolutely from little till great of-them.

12 Because I-shall-be propitious to their unrighteousnesses, and of their sins I by no means might-be still mindful.